

PROFINET

Safety for the future

Products 

Diagnosis 

Monitoring 

Training 

Consulting 



PROFI[®]
NET

Content

Basics	4
Standards and guidelines	5
PROFINET Design Guideline and Commissioning Guideline	5
Parameters for network planning	6
PRONetplan network planning software	8
ETHERtest V5.0/V5.1 and PROlinetest line tester	10
PROscan® Active acceptance test and validation software	11
PROFINET-INspektor® NT analysis and diagnostic tool	14
PNMA II measuring point	17
PROFINET DiagnosticDUO (PROscan® Active & PROFINET-INspektor® NT)	18
PROFINET Diagnostic set	19
PROmanage® NT network monitoring software	20
Configuration example (permanent network monitoring)	22
PROFINET services	23
Products and services	24

Basics

PROFINET is a universal, Ethernet-based communication network that can be used in all areas of automation technology. Speedy vertical and horizontal data exchange across all levels – including the corporate control level – is the foundation for successful systems concepts.



Abb. 1: PROFINET overview

Like PROFIBUS, PROFINET distinguishes between cyclical and acyclical data communication and additionally supports fast IO communication (RT – Real Time and IRT – Isochronous Real Time). This is done while retaining the familiar design with a cyclical transfer of peripheral data between the field devices (IO devices) and the process image in the IO controller. This results in a high degree of flexibility because update rates are scalable (see Fig. 2).

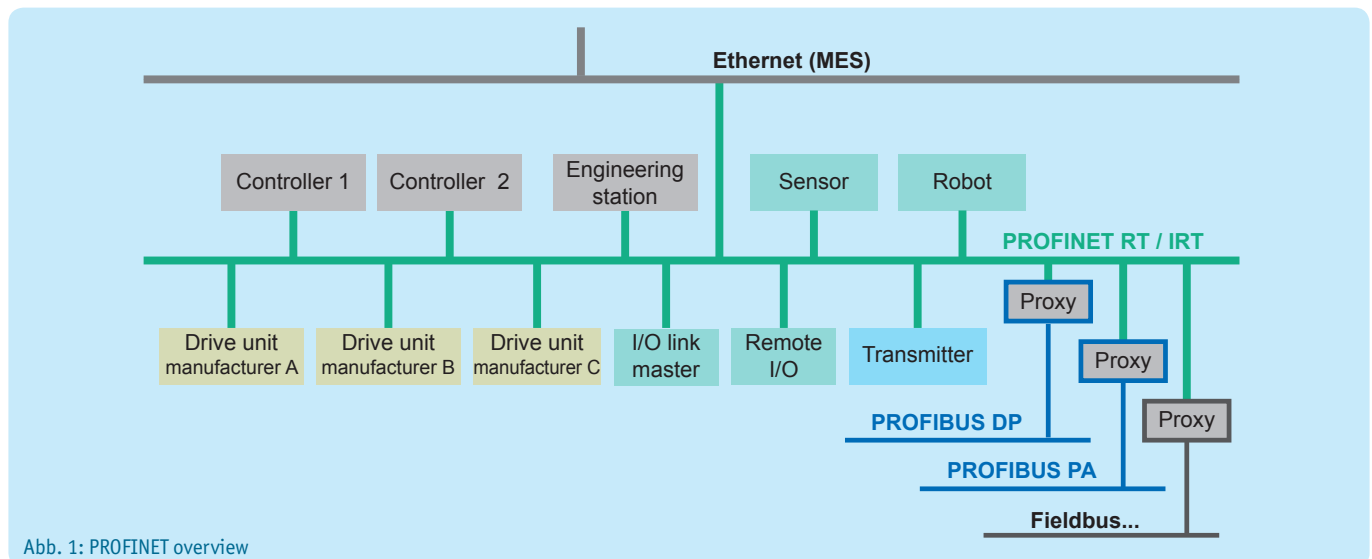
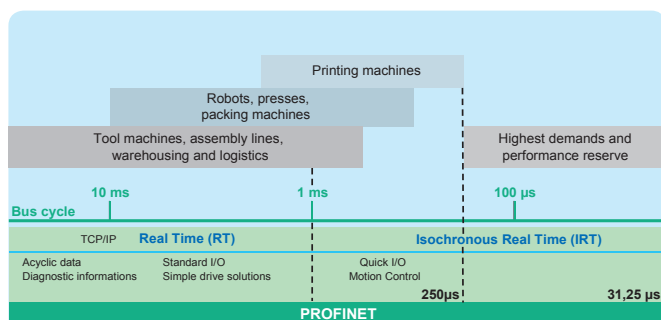

Fig. 2: Scalable bus cycle times (RT and IRT) in PROFINET

PROFINET describes a device model that is based on the principles of PROFIBUS and consists of slots and groups of IO channels (sub-slots). The technical characteristics of the field devices are described by a so-called GSD (General Station Description) that is based on XML.

Data in PROFINET networks is highly varied. Besides prioritized, cyclical PROFINET I/O data, acyclical data (e.g. TCP/IP, diagnostic messages or SNMP requests) can be transmitted (see Fig. 3).

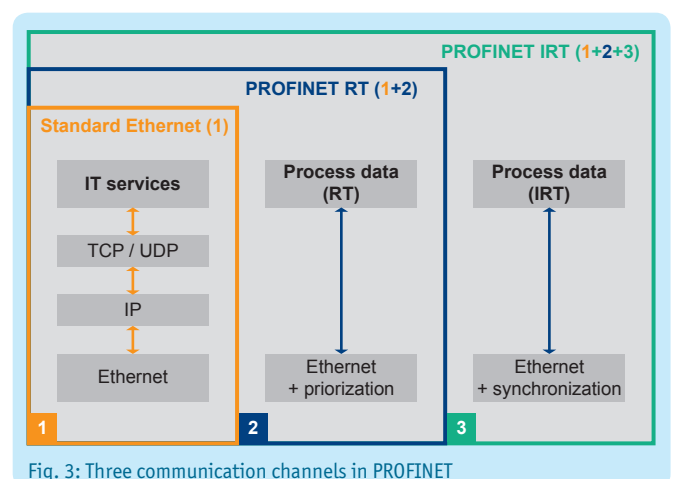

Fig. 3: Three communication channels in PROFINET

Network topologies in PROFINET derive from the requirements of the systems to be networked. The most common structures are star, line, tree and ring-shaped. In practice, systems usually are a mix of the above structures. They can be implemented either with copper or fiber-optic cables.

Standards and guidelines

Measurement, planning, acceptance inspection and commissioning in PROFINET, and therefore the criteria for quality evaluation, are based on observing the following standards and guidelines as well as the experience of **Indu-Sol GmbH**.

- PI PROFINET Design Guideline and Commissioning Guideline – (V1.14 and V1.36) Dec. 2014
- PROFINET I/O Security Level 1 (netload) – Version 1.2 – June 2015
- PI PROFINET Assembly Guideline – (V1.0) Jan 2009
- EN 50173 / ISO IEC 11801 – Structured cabling systems
- EN 50310 – Application of equipotential bonding and earthing in buildings with information technology equipment
- VDI / VDE Guideline 2184 – Reliable operation and maintenance of fieldbus systems

PROFINET Design Guideline and Commissioning Guideline

The extensive options for configuration and utilization of a network necessitate careful planning and practice-oriented commissioning of the system. The user organization PROFIBUS & PROFINET International (PI) has defined quality criteria for planning, acceptance and commissioning, as well as the metrological evaluation of a network in its latest **Design and Commissioning Guideline**. It is intended as a guideline for all persons and organizations involved in the planning, installation, operation and maintenance of such systems.

In the planning stage, network utilization should be considered in addition to structure. For this purpose, it is important to know the relationships between update rate, line depth and network structure. Practical planning tools like **PROnetplan** by **Indu-Sol** can be used to display such relationships in an interactive graphic to avoid weak spots.

Moreover, it is useful to define the requirements for IO devices in advance. The categorization in Conformance Classes (CC-A, CC-B, CC-C) is a useful aid to users when selecting devices that have no more than the required functionality. Requirements include simultaneous access to devices by several controllers (IO controllers), support for media redundancy, detection of topology information in the network, device exchange without repeated use of a parameterization device, as well as applications with very short cycle times and low variation.

The selection and placement of network components in the network structure depends on the performance of the devices. It is described by the net load classes (IO Security Level 1 – see the “standards and guidelines” box).

The years of experience with fieldbus technology have shown that the extensive diagnostic options of controllers in the area of device diagnostics should be expanded by an additional measurement to verify the quality of communication. The measurements serve as dual purpose, namely a description of the PROFINET network on the one hand and ensuring operational reliability on the other. Special attention should be paid to assuring the quality of the line connections (test when plant is stopped) as well as the transmission during operation.

RECOMMENDATION

In order to ensure reliable long-term functionality of the plant, measurements to verify compliance with the quality requirements (pages 7 and 16) are urgently recommended.



Parameters for network planning

Planning the network structure

The key properties of PROFINET are a variable network structure and the unlimited combinations provided by exploiting all topological shapes of the standard Ethernet. The topology results from the following criteria:

- Spatial arrangement of the components
- Distances to be bridged
- Requirements for the use of primary infrastructure / increased availability
- Consideration of netload (netload planning) and TCP/IP traffic
- Update rate in consideration of line depth
- Communication quality and telegram traffic
- Requirements for potential isolation/EMC

Selecting the right topology is important for the further planning of a PROFINET automation system. If required, the topology has to be adapted in a later inspection step.

Sources: PI Design Guideline (V 1.14/Dec. 14) pp. 51-56
PI Commissioning Guideline (V 1.36/Dec. 14) pp. 91/92

Update time

The update rate is the interval at which the data between the controller and IO device is updated. It can be set individually for each device in the controller (standard setting: 2 ms). In addition to considering the requirements of the process, also consider the PLC cycle time. Indu-Sol recommends setting the update time for devices to at least half the PLC cycle time. The guiding principle is **“Update only as necessary – not as much as possible.”** The switching behavior of each device and the installed line depth, i.e. the number of passing devices (switches and IO devices with integrated switches) on the line, are critical for compliance with the update rate. An increasing number of passing devices prolongs the duration of the telegram. The variation of the real from the set update rate keeps increasing. It is called **“jitter”** and indicated in percent. Measurements to show compliance with the set update rates and their variation may serve as a basis for an assessment of system stability and provide an early warning of potential weak spots.

Sources: PI Design Guideline (V 1.14/Dec. 14) pp. 97-99
PI Commissioning Guideline (V 1.36/Dec. 14) p. 104

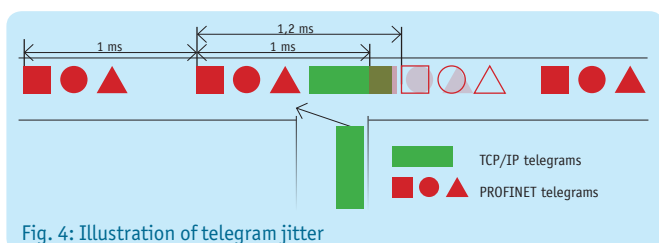

Netload

The cyclical netload generated by each PROFINET device has a maximum in the connection between the controller and the first device. In order to permanently ensure the flawless functioning of the PROFINET network the following tolerances for planning and realization have to be ensured:

Netload	Recommendation
< 20%	No action required
20%... 50%	Review of planned netload is recommended
> 50%	Take action to reduce netload

It can be seen from the practical applications that the existing netload consists of both PROFINET and TCP/IP communication. Although the PROFINET communication is generally prioritized at switches (network nodes), TCP/IP communication may sometimes jump the queue. Whether and to what extent this happens – or can happen – can be seen from the load ratio (PROFINET to TCP/IP communication). Since different netloads (peak loads) affect the compliance with update rates and devices of different netload classes are especially sensitive to peak loads demonstrating the network quality in consideration of utilization is especially important during the acceptance test or troubleshooting of a system.

Sources: PI Design Guideline (V 1.14/Dec. 14) pp. 115-118
PI Commissioning Guideline (V 1.36/Dec. 14) pp. 97/98



Abb. 5: TCP/IP devices are connected unfavorably → higher netload



Abb. 6: TCP/IP devices are connected optimally → low netload

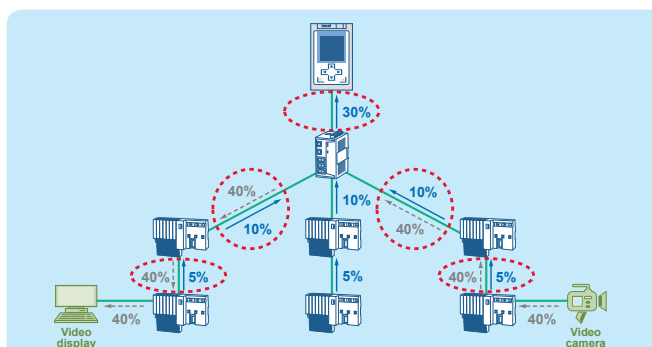

Line depth

Because in PROFINET (RT) it cannot be determined whether a device (switch) is operating in store-and-forward or in cut-through mode a delay has to be expected for every passing device.

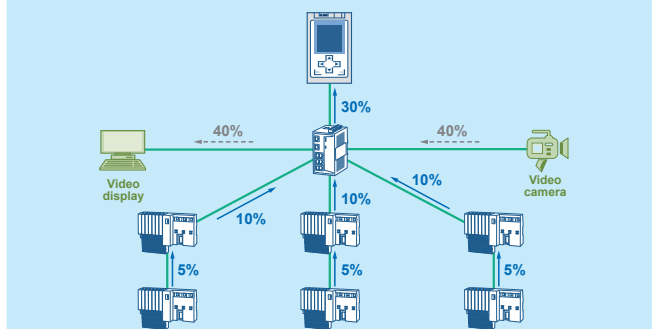
This delay has to be considered when designing a network in the planning phase. Fundamentally, the maximum line depth depends on the update time and the switch mode (see the "line depth" tables). Indu-Sol recommends observing the values from the PI guideline "Line depth for store-and-forward switches".

Source: PI Design Guideline (V 1.14/Dec. 14) pp. 111-114

Line depth for store-and-forward switches

Max. line depth for update time of			
1ms	2ms	4ms	8ms
7	14	28	58

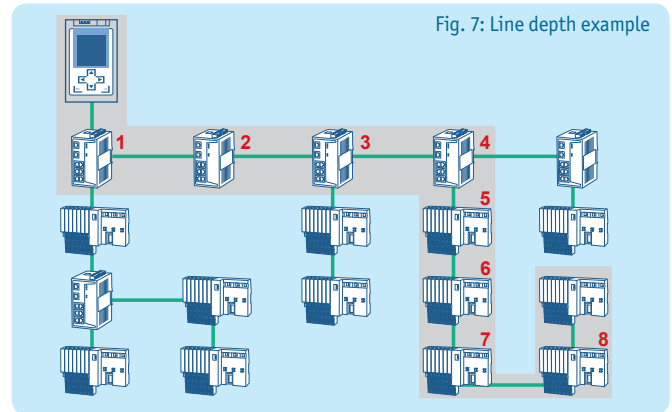

Fig. 7: Line depth example

Line depth for cut-through switches

Max. line depth for update time of			
1ms	2ms	4ms	8ms
64	100	100	100

Access points

When planning PROFINET networks the guideline recommends passive access points for network diagnostics.

Why?

- During commissioning or maintenance, to analyze the network traffic or read out devices
- To connect diagnostic devices during running operation without interruption
- For troubleshooting or long-term diagnosis/preventative maintenance of the network condition

How?

- Using passive, feedback-free TAPs (e.g. **PROFINET measuring point PNMA II** - see page 17)
- Using a smart TAP (e.g. **PROFINET-INSpektor® NT** – see page 14)

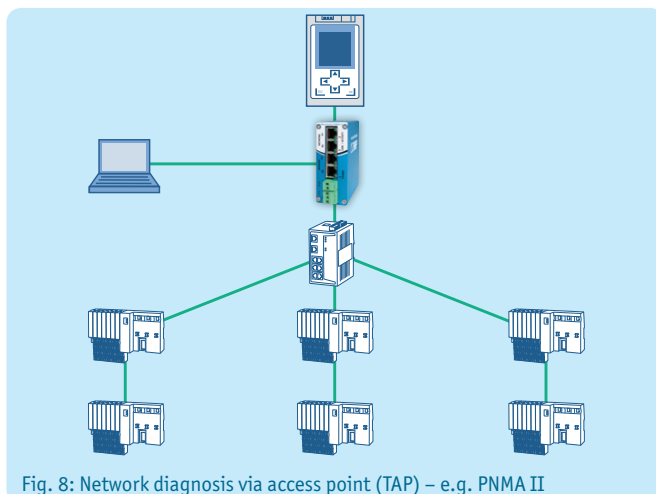

Fig. 8: Network diagnosis via access point (TAP) – e.g. PNMA II

Please note:

In principle, an initial rough analysis of the network traffic (telegram analysis) is also possible via a mirror port on the switch using analysis software (e.g. Wireshark). However, this port only delivers 100 Mbps.

But the cable carries incoming data to the controller at 100 Mbps on one wire pair and outgoing data from the controller at 100 Mbps on the other wire pair. Thus the port of the switch cannot diagnose more than one half of the data flow.

Source: PI Design Guideline (V1.14/Dec. 14) pp. 90-91

RECOMMENDATION – Quality values

Recommendations on the quality values in PROFINET by Indu-Sol

Jitter (deviation from the planned update time)	≤ 50 %
Telegram gap (missing telegram)	0
Error telegram (defective telegrams)	0
Load ratio (How heavily the network is loaded?)	100 : 1
Netload (in 100 Mbps)	< 20 %

PROnetplan network planning software

PROnetplan is a software for the preliminary planning of industrial networks. The network can be assembled intuitively on a graphic interface. Important parameters like the net load at the controller are calculated and displayed automatically based on the line depth and the preset update rate. With a simple simulation of the communication parameters or changes in the network structure, potential bottlenecks can be identified and eliminated during the planning stage. All devices and the predicted net load for each interface are listed in a clear overview. Free switch or device ports as well as the line depth are shown for each device. A special feature is the automated notification

about the impact on net load when integrating components with TCP/IP communication. As in real hardware configuration the update rate can be set uniformly for all devices or separately for each device. Security pop-ups show the locations in a network where the use of a firewall would be advisable.

In addition to network optimization, the topology created with **PROnetplan** may serve both as a platform for discussion with the customer and as a document for network installation.

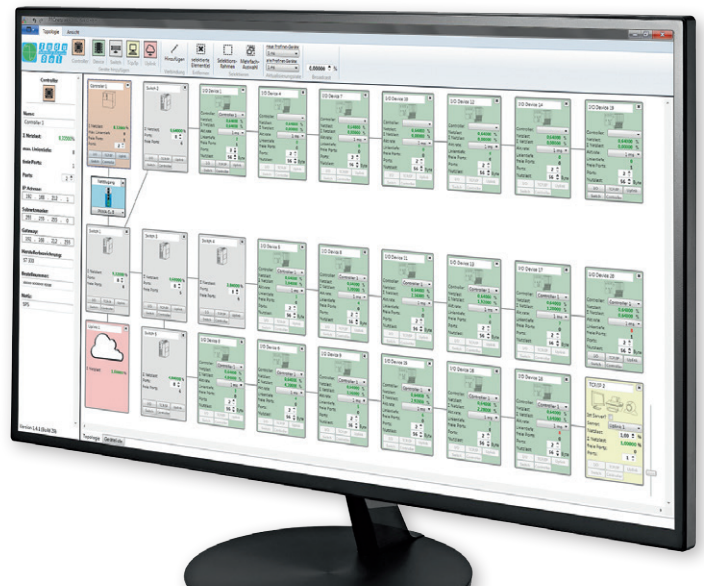
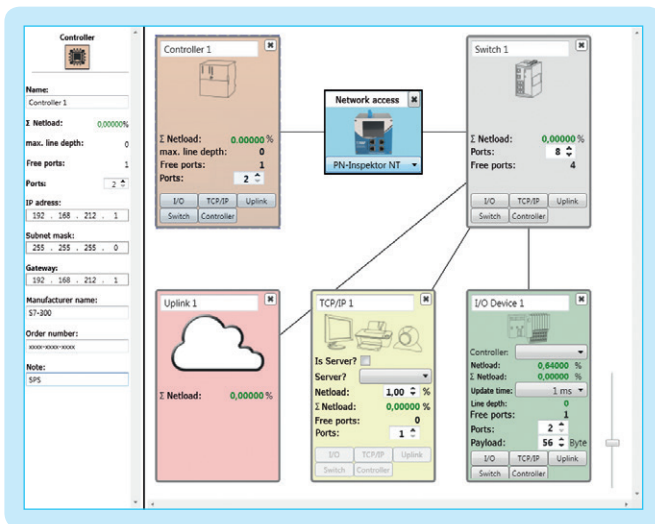

PROnetplan

Device type	Device name	Number of ports	Free ports	Netload (Byte)	Netload generated (%)	Local netload (%)	Allocated controller
Controller	Controller 1	2	1		0	7,4	
Switch	Switch 1	8	4		0	7,4	
Switch	Switch 2	8	6		0	2,56	
Switch	Switch 3	8	5		0	4,84	
Uplink	Uplink 1	1	0		0	0	
IO Device	IO Device 1	2	0	56	0,64	2,56	Controller 1
IO Device	IO Device 2	2	0	56	0,64	1,92	Controller 1
IO Device	IO Device 3	2	0	56	0,64	1,28	Controller 1
Switch	Switch 4	8	6		0	1,92	
IO Device	IO Device 5	2	0	56	0,64	1,92	Controller 1
IO Device	IO Device 6	2	0	56	0,64	1,28	Controller 1
Switch	Switch 5	8	6		0	2,92	
IO Device	IO Device 8	2	0	56	0,64	2,92	Controller 1
IO Device	IO Device 9	2	0	56	0,64	2,28	Controller 1
IO Device	IO Device 4	2	1	56	0,64	0,64	Controller 1
IO Device	IO Device 7	2	1	56	0,64	0,64	Controller 1

Fig. 9: All devices are shown in a clear device list (including all relevant parameters)



Automatically generated detail information:

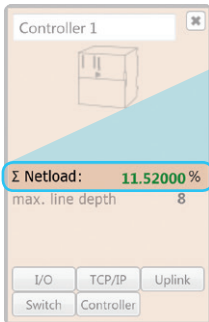

Netload

Σ Netload: **11.52000 %**

PRONetplan dynamically shows the resulting load for every connection in the network. This also applies with complex network structures or networks with multiple controllers.

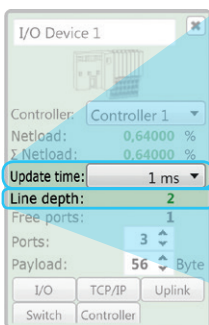

Update time

Update time: **1 ms**

The update rate can be set uniformly for all devices or separately for each device.

Line depth

Line depth: **2**

PRONetplan shows the line depth dynamically for each device. The communication partner can be assigned for every device in the network.

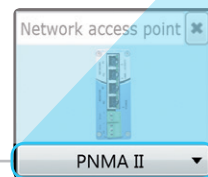

Network access

PNMA II

All net access devices are shown in the software and can be considered in the planning phase.

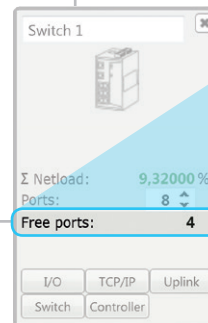

Free ports

Free ports: **4**

Displays remaining free ports on switches and devices.

Payload

Payload: **56** Byte

For a more accurate calculation of the netload the real netload can be set for each device in the expanded view.

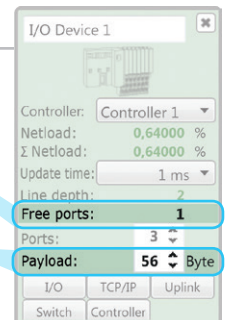

Free ports: **1**

Payload: **56** Byte

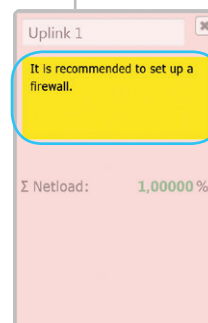

Security information

It is recommended to set up a firewall.

The user-friendly pop-ups with security information show immediately which devices have free ports that may need to be blocked and where the use of a firewall might be advisable.

Highlights

- Display of the netload for every connection in the network
- Update rate setting
- Indication of line depth for every device
- Separate netload settings for each device
- Definition of different network access devices, e.g. **PROFINET-INspektor® NT** or the **PNMA II** measuring point
- Clear device list for all devices
- Pop-ups with security information
- Display of remaining free ports on switches and devices
- Full-featured printer functionality
- PDF export with numerous functions

PRONetplan in conjunction with PROscan® Active

The topologies scanned with the **PROscan® Active** analysis software (see page 11) can easily be fed into **PRONetplan**. This enables a comparison between the plan and reality. This procedure is very useful during an expansion or optimization of the network.



ETHERtest V5.0/V5.1 and PROlinetest line tester

Certification and acceptance

The **ETHERtest V5.0** line provides for all measurements required for the acceptance and certification of network cables up to Class FA/Category 6A (1000 MHz). Not only line length but also attenuation, resistance, crosstalk (NEXT), delays, shielding and the proper contacts (connection schematic) are measured and evaluated. Beyond the certification of copper cables, attenuation and OTDR can be measured for single and multi-mode fiber optic cables by means of additional adapters (**ETHERtest V5.1**).

All recorded values are displayed graphically, which enables the error sources to be identified and localized with an accuracy of 10 centimeters. All measurements are stored automatically in the device and can be retrieved as measurement report using PC software.

Verification and troubleshooting

PROlinetest is an indispensable tool for all those who install or troubleshoot PROFINET systems. The device detects any wiring errors and tests the wires and wire pairs for continuity, breaks, short-circuits, cross-wiring and exceeded maximum cable lengths.

The measurement of the total cable length and the distance to the error location significantly simplifies troubleshooting. The adapter can also be used to check Drive-Cliq and M12 cable systems.

Source: PI Commissioning Guideline (V1.36/Dec.14) pp. 47-62



Fig. 10: ETHERtest V5.0

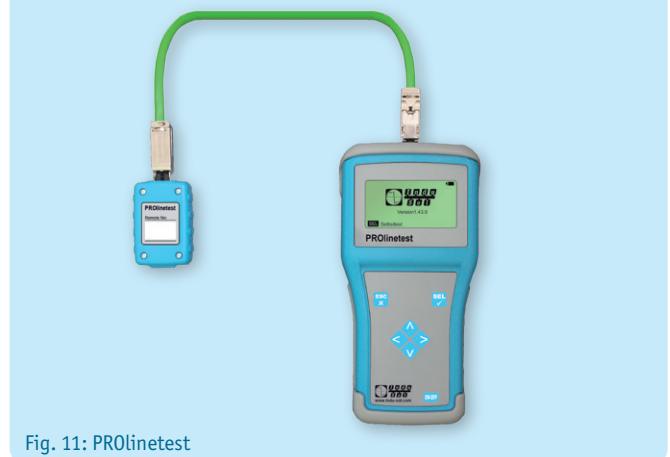

Fig. 11: PROlinetest

RECOMMENDATIONS – Line lengths and attenuation

Compliance with the limit values acc. to Cat. 5e/Class D+ is monitored for a maximum length of 100 m, i.e. 24 dB attenuation. This means that with a shorter cable (e.g. 10 m) compliance is monitored only for the maximum attenuation of 24 dB.

Cable length	Max. attenuation acc. to standard Cat. 5e for 100 MHz	Length-dependent max. attenuation, Indu-Sol GmbH	Length-dependent recommended max. attenuation by Indu-Sol GmbH
100,0 m	24dB	24dB	21dB
50,0 m	24dB	21dB	18dB
25,0 m	24dB	18dB	15dB
12,0 m	24dB	15dB	12dB
6,0 m	24dB	12dB	9dB
3,0 m	24dB	9dB	6dB
1,5 m	24dB	6dB	3dB

The qualitative evaluation of **attenuation** should be performed in consideration of line length.

Weak spots are therefore not detected early. For this reason, all measurement results for attenuation and crosstalk should be evaluated against the cable length using the following tables.

Cable length	Max. attenuation acc. to standard Cat. 5e for 100 MHz	Length-dependent max. attenuation, Indu-Sol GmbH	Length-dependent recommended max. attenuation by Indu-Sol GmbH
100,0 m	30 dB	30dB	33dB
50,0 m	30 dB	33dB	36dB
25,0 m	30 dB	36dB	39dB
12,0 m	30 dB	39dB	42dB
6,0 m	30 dB	39dB	42dB
3,0 m	30 dB	39dB	42dB
1,5 m	30 dB	39dB	42dB

The qualitative evaluation of **crosstalk (NEXT)** should be performed in consideration of line length.



PROscan® Active

PROscan® Active acceptance test and validation software

Online analysis / topology scan

With the **PROscan® Active** software you can generate a detailed description of your PROFINET networks online during running production at any time. Thanks to PROFINET devices' integrated LLDP protocol (detection of neighborhood relationships) it is possible to generate a complete topology map including all designations and connections in an extremely short time, and thereby simultaneously perform an initial simple diagnosis (line interruptions, device failures etc.) during operation. Other strengths of this product include flexible options for integration into existing plants and a simple, intuitive user interface.

The software helps to efficiently organize a complex network and, if required, perform necessary maintenance in a timely and direct manner. Its low resource requirements enable **PROscan® Active** to be installed on any commonly available touch panel.

Source: PI Commissioning Guideline (V.1.36 / Dec. 14) pp. 91/92

Highlights

- Optimized for touch panel
- Easy to use
- Resource-saving
- Node information
 - PROFINET name
 - IP-/MAC address
 - Subnet mask
 - Gateway
 - Hardware/software version
 - Device version/name
 - Order number
- Line information
 - Line length
 - Attenuation reserve (polymer fibers)
 - Breaks
- Port statistics

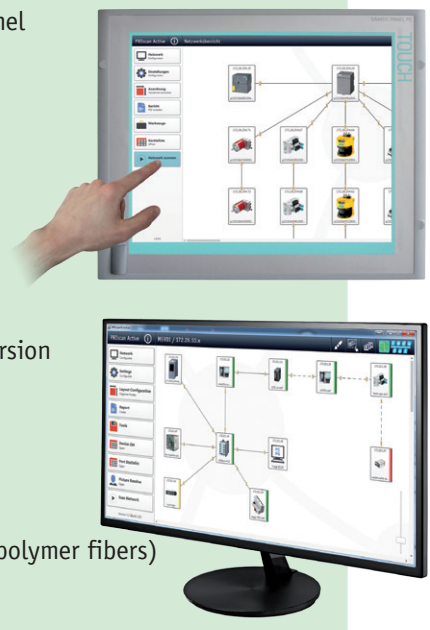

➤ **Advanced printing and export functions (PDF)** ➤ **comprehensive documentation options**

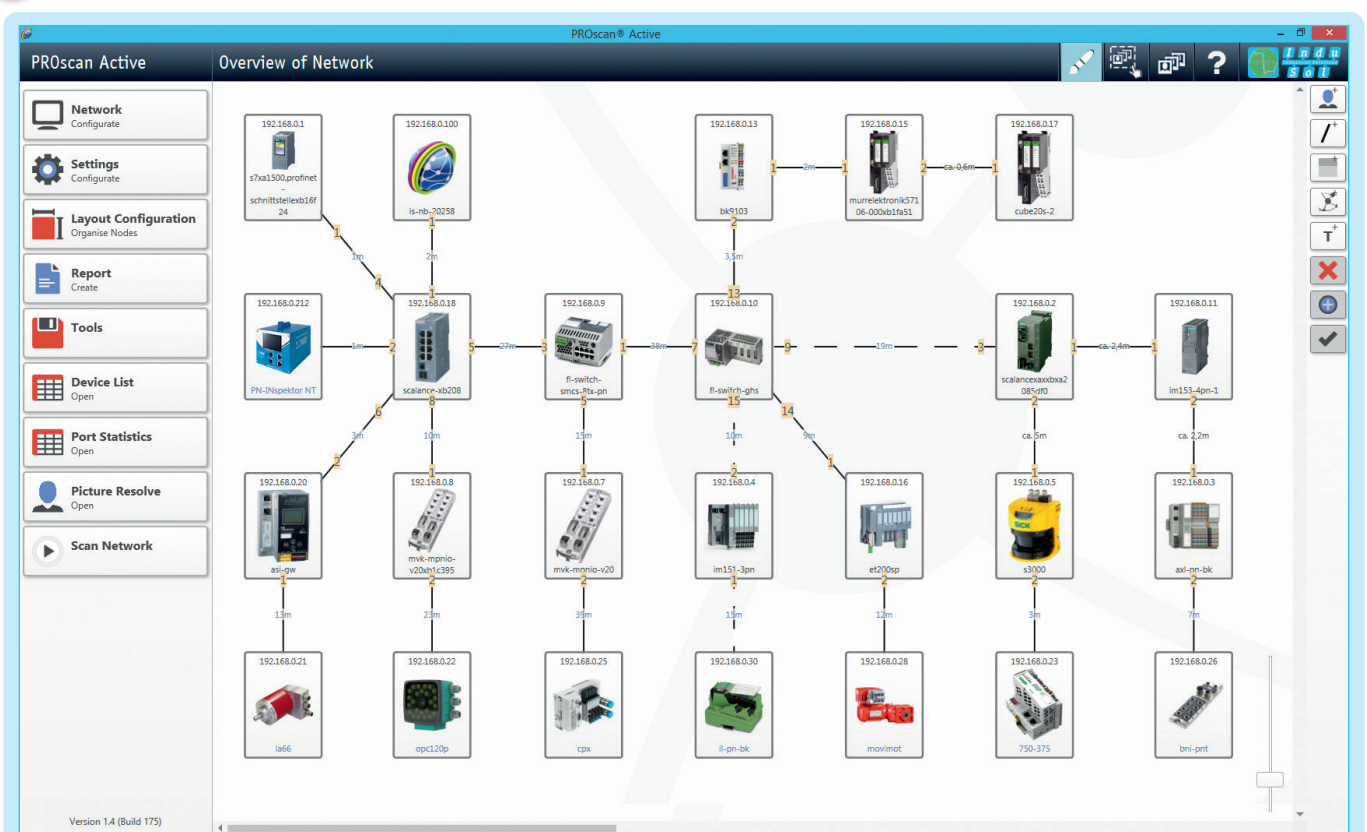

Fig. 12: PROscan® Active – clear visualization of the network topology



PROscan® Active acceptance test and validation software

Device list

In addition to the device information (manufacturer, ordering details), the automatically generated device list also gives a quick overview of the hardware and firmware versions of all devices used, allocating the device names, IP and MAC

addresses accordingly. The evaluation of this data can be exported into an acceptance-relevant report at the push of a button.

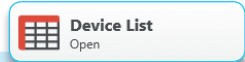

Device type	IP addresses	Subnet	Gateway	MAC adress	Device name	HW version	SW version	Device type name	Order number	Vendor ID	Device ID	Controller	RealTime Class
	172.20.1.51	255.255.255.0	172.20.1.51	00:1B:1B:72:7E:89	x208-cu-zeile4	6	V4.5.0	SCALANCE X-200	6GK5 208-0BA10-2AA3	42	2561	controller-tafel	RTClass2
	172.20.1.54	255.255.255.0	172.20.1.54	00:A0:45:68:20:F9	phoenix-switch-zeile3	5	V3.80.0	FL SWITCH SMCS 8TX-PN	2989103	176	78	controller-tafel	RTClass2
	172.20.1.55	255.255.255.0	172.20.1.55	00:1B:1B:34:83:A6	x202-pof-zeile2	5	V5.0.22	SCALANCE X-200	6GK5 202-2BH00-2BA3	42	2561	controller-tafel	RTClass2
	172.20.1.56	255.255.255.0	172.20.1.56	00:1B:1B:1E:1B:21	et200s-pn-pof-zeile3	2	V7.0.1	IM151-3	6ES7 151-3BB23-0AB0	42	769	controller-tafel	RTClass2
	172.20.1.58	255.255.255.0	172.20.1.58	00:0E:8C:D7:E3:32	x208-cu-zeile1	4	V4.5.1	SCALANCE X-200	6GK5 208-0BA10-2AA3	42	2561	controller-tafel	RTClass2
	172.20.1.59	255.255.255.0	172.20.1.59	00:1B:1B:24:DA:80	et200m-pn-zeile1	2	V4.0.0	IM153-4	6ES7 153-4AA01-0XB0	42	770	controller-tafel	RTClass2
	172.20.1.60	255.255.255.0	172.20.1.60	00:1B:1B:3A:EC:7E	x208-cu-zeile5	6	V4.5.1	SCALANCE X-200	6GK5 208-0BA10-2AA3	42	2561	controller-tafel	RTClass2
	172.20.1.64	255.255.255.0	0.0.0.0	00:80:63:66:54:B0	octopus-zeile7	130	V4.2.3	Hirschmann OCTOPUS	6GK5 208-0BA10-2AA3	42	2561	controller-tafel	RTClass2
	172.20.1.65	255.255.255.0	172.20.1.65	00:16:77:00:8F:A1	pn-asi-gw-zeile5	2	V2.0.0	AS-i	BWU1912	289	1912	controller-tafel	RTClass2
	172.20.1.70	255.255.255.0	172.20.1.70	00:0F:9E:05:30:47	murr-mvk-rechts1	1	V3.1.0	MVK ProfiNet	55288	303	289	controller-tafel	RTClass2
	172.20.1.71	255.255.255.0	172.20.1.71	00:90:E8:3D:1D:BD	eds-510e	100	V4.0.0	MOXA EtherDevice Switch	0054-000510-E000	553	84	controller-tafel	RTClass2
	172.20.1.74	255.255.255.0	172.20.1.74	00:01:05:16:EE:87	bk9103			BK Device		288	9000		
	172.20.1.75	255.255.255.0	172.20.1.75	00:0F:9E:05:2F:CF	murr-mvk-links1	1	V3.1.0	MVK ProfiNet	55288	303	289	controller-tafel	RTClass2
	172.20.1.80	255.255.255.0	0.0.0.0	00:06:71:26:00:7A	pn-inspektor-v1			PROFINET INspektor		273	256		
	172.20.1.81			00:06:71:20:00:37	„PB-INSpektor V2“								
	172.20.1.82			00:16:77:00:28:9C	ASI-INSpektor								

Port overview

In addition to the device list with all device-relevant data, a list of port relevant data for each device is also available. The overview shows both the line lengths of copper and polymer fiber connections as well as the attenuation reserve of polymer fiber connections.

Information on defective or rejected telegram packets (CRC error or discards) is important for detecting weaknesses and to perform an error analysis.



Number	Name	Connected with	Line type	Length	Send power budget	Remote power budget	Connection	InDiscards	OutDiscards
172.20.1.200 (controller-tafel)									
2	port-002	172.20.1.55 (x202-pof-zeile2)	Copper	ca. 58,6m			100BaseTXFD	0	78
172.20.1.54 (phoenix-switch-zeile3)									
1	port-001	172.20.1.60 (x208-cu-zeile5)	Copper	17,2m			100BaseTXFD	0	0
2	port-002	172.20.1.51 (x208-cu-zeile4)	Copper	47,1m			100BaseTXFD	0	0
3	port-003	172.20.1.248 (inblox)	Copper	5,0m			100BaseTXFD	0	0
4	port-004	172.20.1.82 (ASI-INSpektor)	Copper	5,0m			100BaseTXFD	0	0
5	port-005	172.20.1.81 („PB-INSpektor V2“)	Copper	5,0m			100BaseTXFD	0	0
172.20.1.55 (x202-pof-zeile2)									
1	port-001	172.20.1.200 (controller-tafel)	Copper	ca. 58,6m			100BaseTXFD	0	0
2	port-002	172.20.1.71 (eds-510e)	Copper	10,5m			100BaseTXFD	0	0
3	port-003	172.20.1.56 (et200s-pn-pof-zeile3)	Fibre-optic Cable	20,5m	4,2db	10,8db	100BaseTXFD	0	0
172.20.1.56 (et200s-pn-pof-zeile3)									
1	port-001	172.20.1.55 (x202-pof-zeile2)	Fibre-optic Cable	20,5m	10,8db	4,2db	100BaseTXFD	0	0



PROscan® Active

Explanations (Discards/Error telegrams)

Data packets may be discarded by the switch, e.g. because of malfunctions, transmission errors or queue overflow at the switches.

PROscan® Active determines the number of such discards (see Fig. 13) and the number of defective telegrams (CRC errors) from the devices and displays them in a table. This provides clues as to potential causes of error.

During the analysis of such information special attention needs to be paid to devices in communication lines with high load.

Source: PI Commissioning Guideline (V 1.36 / Dec. 14) pp. 95/96

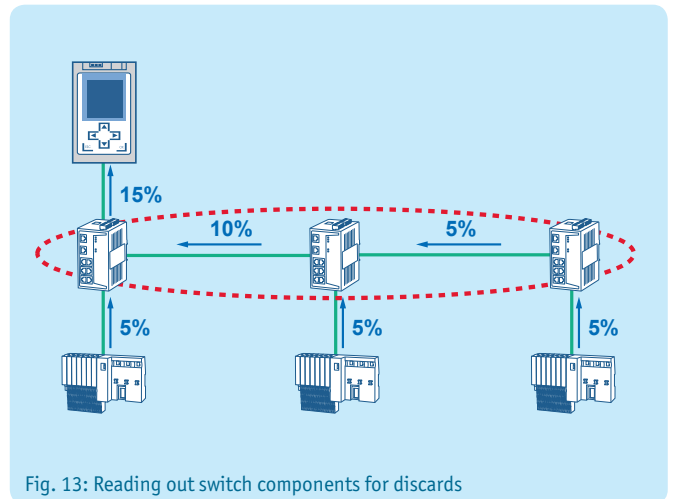

Fig. 13: Reading out switch components for discards

Checking the system reserve for optical cabling

If using polymer optical fiber (POF), the optical system reserve (power budget) of every single connection can be determined in online operation. It is a measure for the available optical power reserve between transmitter and receiver to ensure trouble-free operation. It can be read out and displayed as a diagnostic value. If the attenuation reserve of a POF connection falls below 5 dB, it is immediately apparent where transmission problems might occur.

These are represented by an exclamation mark \triangle in the connection. This enables you to detect and remedy the weaknesses in your system at any time.

Source: PI Commissioning Guideline (V 1.36 / Dec. 14) pp. 88/89



PROscan® Active

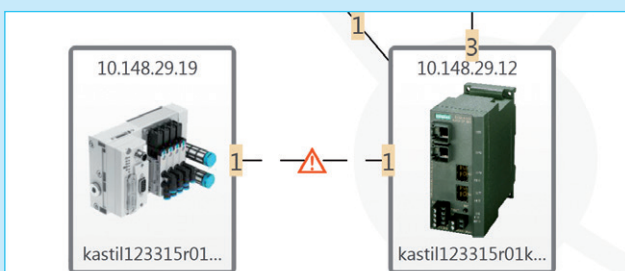

Fig. 14: Display when transmission problems occur

System reserve	Evaluation
> 6 dB	The value is above the measurement range. No action required.
> 2 dB to 6 dB	The value is within the valid measurement range. Trouble-free communication is ensured. Typical values for cabling without other plug-in connections: <ul style="list-style-type: none"> • 5 dB for cable lengths up to 30 m • 3,5 dB for cable lengths from 30 m to 40 m • 2,5 dB for cable lengths from 40 m to 50 m In case of deviation from the listed value ranges a cable inspection is recommended (check for additional plug-in connections, attenuation check).

PROFINET-INSpektor® NT analysis and diagnostic tool

The **PROFINET-INSpektor® NT** is an intelligent, passive measurement and diagnostic tool for temporary or permanent monitoring of PROFINET networks. Due to its passive and feedback-free behavior it is highly suitable for online analysis.

The **PROFINET-INSpektor® NT** is both a full-featured measuring device for network acceptance and a tool for condition monitoring.

Network parameters – Quality parameters

All subsequently listed quality parameters are detected as events, evaluated, cached and displayed in a clear overview.

- Network load
- Telegram jitter
- Load ratio (broadcast and multicast net loads)
- Update times
- Device diagnoses
- Device failures
- Telegram gaps
- Error telegrams
- Telegram overtakes

Highlights

- Display that shows errors directly
- Netload display with millisecond accuracy
- Alarms in case of unknown devices
- Choice of active or passive network diagnostics
- Network anomaly detection
- Seamless monitoring even for high network loads

Start time: 23.07.2015 16:06:22
End time: 23.07.2015 16:06:33

Siemens_24:DA:80 (192.168.0.10)
Telegram jitter 112%
Alert (low priority) 1

PhoenixC_38:5F:34 (192.168.0.6)
Failures 1

Murrelek_FE:B9:DE (192.168.0.16)
Telegram gaps 1

PN-INSpektorNT

Device is connected

✓ Error free since 64 days

Network overview

Node overview

Resolve MAC address Display

Show acyclic nodes

Show PROFINET nodes

Current	Last minute	History
PhoenixC_38:5F:34 210%	Siemens_1C:CA:44 145%	Siemens_34:83:A6 10%
Beckhoff_16:EE:87 36%	Murrelek_FE:B8:DE 245%	Murrelek_FE:B9:DE 120%
Sick_02:31:0A 14%	PhoenixC_68:20:F9 18%	Siemens_C8:8E:78 12%
Siemens_C8:8E:7D 8%	PhoenixC_BE:E7:39 20%	PhoenixC_BE:E7:26 102%
		Siemens_1E:1B:21 43%
		Siemens_24:DA:80 112%
		Siemens_2C:F7:C 255%
		Murrelek_05:30:47 25%
		Murrelek_05:2F:C 33%
		Fujitsu_18:5F:4F 32%

Key

Active Warning Error Inactive

Controller Acyclic Inactive

Unacknowledged error messages 22

Current bus status Very good

Indu-Sol GmbH

PROFINET-INSpektor® NT

Fig. 15: Clear, detailed device overview with selection of each network parameter



PN-INspektor® NT

Device information

	Last minute			History		
MAC address	Siemens_2C:F7:C0					
IP address	192.168.0.6					
Name						
Alias						
Vendor						
Vendor ID	0					
Device ID	0					
Device role						
Alert (low priority)	0			28		
Alert (high priority)	0			0		
Failures	0			15		
Telegram gaps	0			3,543		
Telegram overtakes	0			0		
	min	avg	max	min	avg	max
Set update rate	2ms	-	2ms	2ms	-	2ms
Measured update rate	1.99ms	2.00ms	2.01ms	1.95ms	2.00ms	2.05ms
Jitter	-0.7%	-0.1%	0.5%	-2.4%	-0.1%	2.3%
Netload (sent per sec)	0.26%	0.26%	0.26%	0.00%	0.26%	0.27%
	32,00 kB	32,00 kB	32,06 kB	0,00 B	32,00 kB	34,34 kB
Netload (received per sec)	0.27%	0.27%	0.27%	0.00%	0.27%	0.29%
	34,00 kB	33,99 kB	34,00 kB	0,00 B	33,99 kB	35,96 kB

Network statistics

	Last minute	History
Load ratio	1 : >500	1 : >500
Broadcasts/Multicasts (of these PROFINET)	0 (0 0%)	0 (0 0%)
Frames (sent) (of these PROFINET)	30.002 (30.002 100.00%)	144.101.705 (144.101.526 100.00%)
Frames (received) (of these PROFINET)	30.000 (30.000 100.00%)	144.092.515 (144.092.345 100.00%)
Bytes (sent) (of these PROFINET)	1,92 MB (1.92 MB 100.00%)	9,22 GB (9.22 GB 100.00%)
Bytes (received) (of these PROFINET)	2,04 MB (2.04 MB 100.00%)	9,80 GB (9.80 GB 100.00%)
Error telegrams (sent) (of these PROFINET)	0 (0 0%)	0 (0 0%)
Error telegrams (received) (of these PROFINET)	0 (0 0%)	0 (0 0%)

Netload visualization (see Fig. 16)

While other diagnostic devices determine the network load by the second or even the minute, the **PROFINET-INspektor® NT** measures netload by the millisecond and displays it. This makes even minimal load changes in a network detectable. Even in the millisecond range peak loads may cause significant disturbances in the network which would not be detectable without this analysis.

Such short-term peak loads may be caused, e.g. by erroneous hardware settings or active diagnostic tools that continuously send queries into the network.

The network should always be monitored for a consistent netload and any sources of disturbances should be removed. Continuous, passive analysis as provided by the **PROFINET-INspektor® NT** is an indispensable prerequisite.

Please note:

According to the current certification guideline PROFINET devices are tested and specified with a maximum load per millisecond between 1 and 10%, depending on the netload class.

Source: PROFINET I/O Security Level 1 (Netload) – Version 1.2 – June 2015

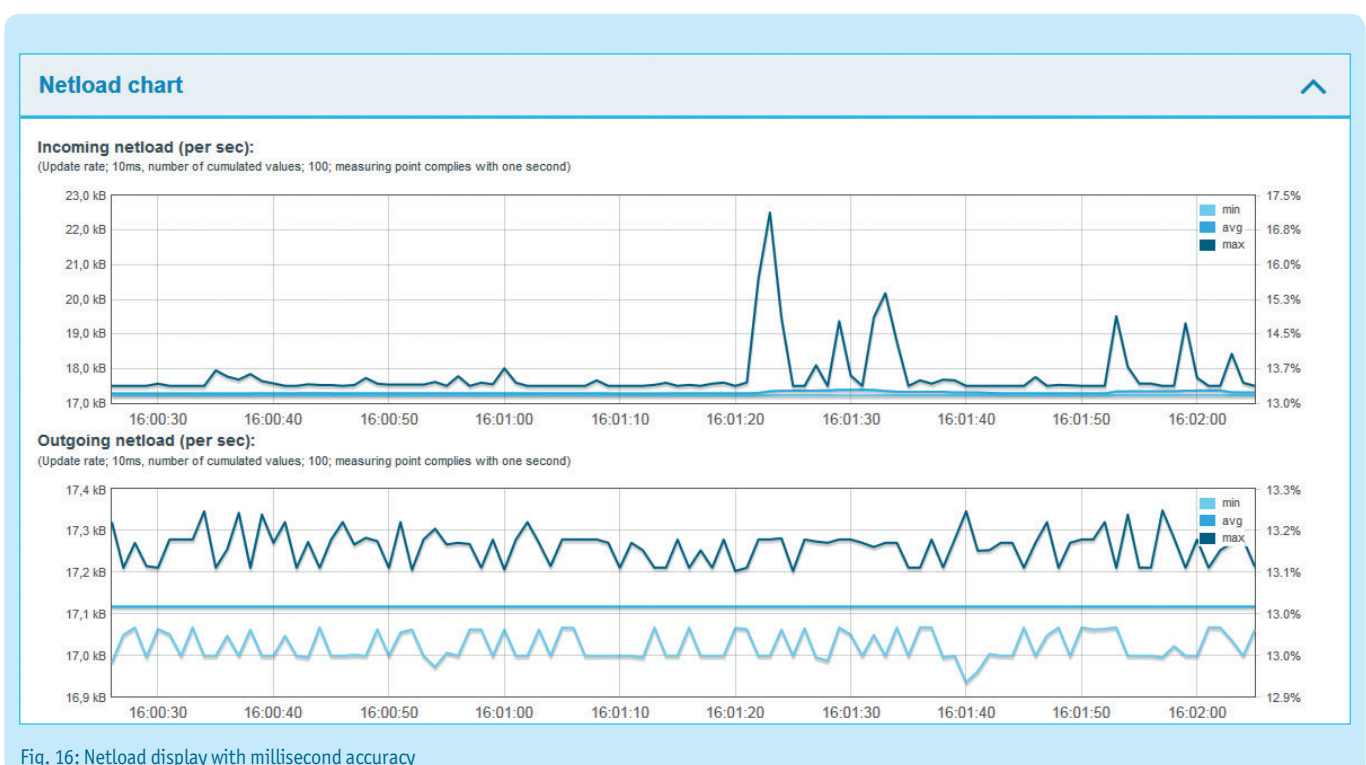

Fig. 16: Netload display with millisecond accuracy



PN-INSpektor® NT

PROFINET-INSpektor® NT analysis and diagnostic tool

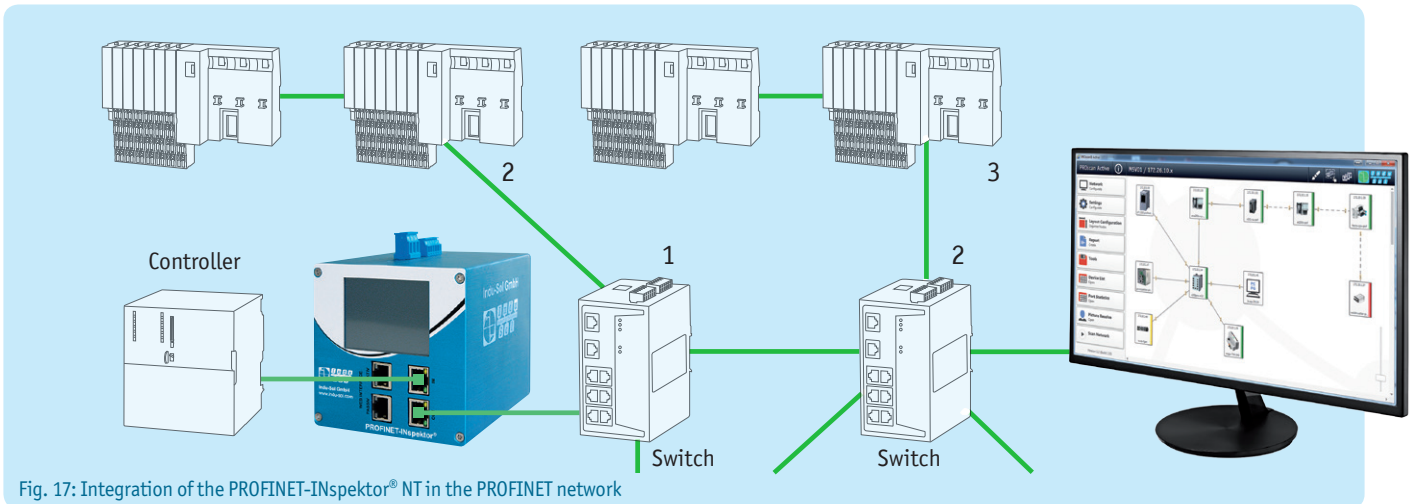

Fig. 17: Integration of the PROFINET-INSpektor® NT in the PROFINET network

Trigger function – Alarms

Trigger functions enable the setting of quality parameters for the network as a whole, but also individually for each device if required.

In the event of changes that exceed the preset thresholds alarm messages (SNMP, email, web interface) are sent or displayed directly via a potential-free contact. The **PROFINET-INSpektor® NT** has an integrated web server and a freely selectable IP address. This enables a visualization of the network condition by means of an Internet browser on any PC, on site or remotely.

In addition to each alarm message telegram copies are stored on the **INSpektor®** and can be downloaded via the web interface for a more detailed error evaluation.

Type	Device	Event	Date	
Status change	00:01:05:16:EE:87	✓ → ! Jitter	26.10.2015 17:49:59.316	📄
Status change	28:63:36:2C:F7:C0 192.168.0.6	✗ → !	23.10.2015 14:32:20.171	📄
Status change	28:63:36:85:B1:B8 192.168.0.1	✓ → ! Telegram gaps	23.10.2015 14:31:21.983	📄
Status change	28:63:36:2C:F7:C0 192.168.0.6	✓ → ✗ Bus node failure	23.10.2015 14:31:18.777	📄
Status change	28:63:36:2C:F7:C0 192.168.0.6	✗ → !	23.10.2015 13:52:41.164	📄
Status change	28:63:36:85:B1:B8 192.168.0.1	✓ → ! Telegram gaps	23.10.2015 13:51:32.572	📄
Status change	28:63:36:2C:F7:C0 192.168.0.6	! → ✗ Bus node failure	23.10.2015 13:51:27.861	📄
Status change	28:63:36:2C:F7:C0 192.168.0.6	✓ → ! Alert (low)	23.10.2015 13:51:27.665	📄

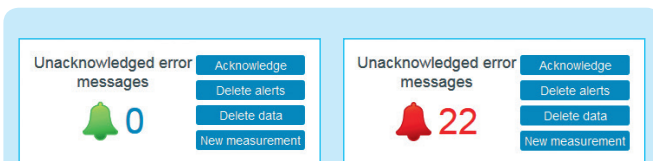

Fig. 18: Display of alarms in the overview screen

User-friendly display of network conditions with traffic light colors and time graphs enable any user to respond quickly in an emergency and ensure a good general overview.

RECOMMENDATION – Quality values

Recommendations on the quality values in PROFINET by **Indu-Sol**

- Jitter**
(deviation from the planned update time) ≤ 50 %
- Telegram gap**
(missing telegram) 0
- Error telegram**
(defective telegrams) 0
- Load ratio**
(How heavily the network is loaded?) 100 : 1
- Netload**
(in 100 Mbps) < 20 %



PNMA II

PNMA II measuring point

The **PNMA II** provides feedback-free access for telegram recording in the PROFINET and other Ethernet-based networks during running production. We recommend installing the **PNMA II** measuring point permanently in the network connection between the automation device (controller) and the first switch, because the major part of the communication typically passes through here.

Function

For the feedback-free connection of an analysis tool (e.g. **PROFINET-INspektor**[®] NT or laptop) two monitor sockets (M1 and M2) are available on the **PNMA II** for diagnostics. This means both communication directions can be monitored simultaneously.

An analysis tool is connected to the monitor sockets by means of two network cables. For analysis and evaluation of the measurement results the telegrams from both communication directions can be overlaid. The **PNMA II** does not discard error telegrams. Instead, it forwards them.

Highlights

- If connecting a **PROFINET-INspektor**[®] NT via a **PNMA II**, only two additional patch cables are needed (no crossover cable required).
- In case of a power supply failure the PROFINET communication via the **PNMA II** remains intact.
- Power supply of additional analytic tools via the UOUT (24VDC) connector

Properties

- Monitoring of all protocols
- Supports all packet sizes
- No packet loss
- All connection ports on the front panel
- No additional effort to connect a measuring device
- Tested interaction with the **PROFINET-INspektor**[®] NT
- No free switch port necessary
- Bi-directional data transmission up to 100 Mbps
- No network interruption when connecting diagnostic tools

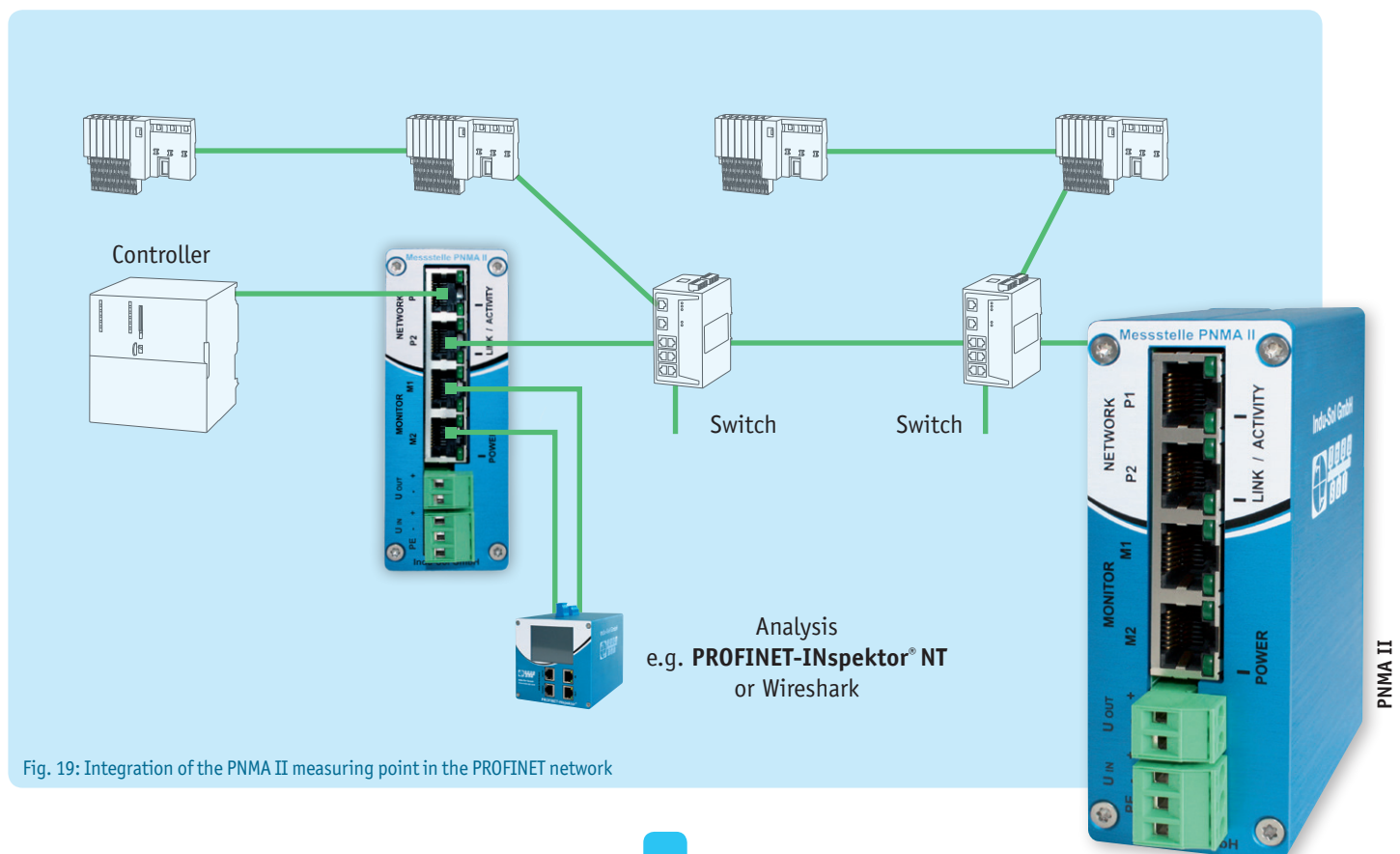

Fig. 19: Integration of the PNMA II measuring point in the PROFINET network

PROFINET DiagnosticDUO (PROscan® Active & PROFINET-INspektor® NT)

Combined, the **PROscan® Active** software and the passive data collector **PROFINET-INspektor® NT** form the perfect navigation system for your network: the **PROFINET DiagnosticDUO**.

Thanks to the teamwork between a live topology map and a diagnostic display the position of each device can be found immediately and its "health status" can be assessed. This enables you to respond promptly and directly to any irregularities.

Intuitive traffic-light colors provide a network analysis at a glance.

Highlights

- First user-friendly topological visualization of in-depth network analysis
- Continuous analysis of the communication quality (network load, telegram gaps, jitter etc.)
- Device status is indicated graphically with traffic-light colors in the topology
- Retrieval of current device list (PROFINET name, IP/MAC address, hardware/software versions, device types etc.)



IO link diagnostics

In addition to the PROFINET diagnostics IO link diagnostics become available for the first time. The transition from PROFINET to the IO link is displayed as well as a port overview where IO link device are connected.

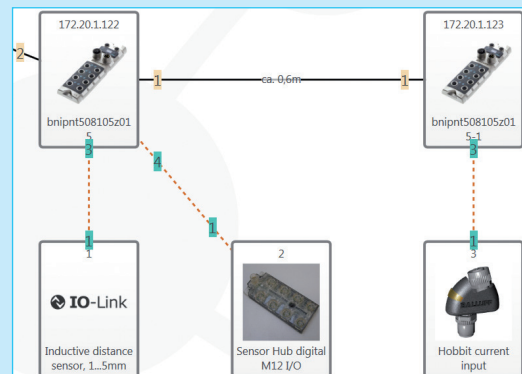
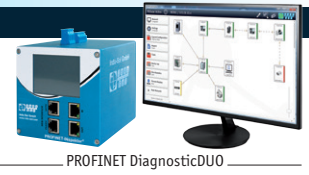

Fig. 20: IO link diagnostics



Teamwork – PROFINET DiagnosticDUO

Both tools can be joined together by activating the function “Read out **PROFINET-INspektor® NT**” in the **PROscan® Active** software. This gives you a navigation system for your PROFINET network so you can see the status of all devices displayed graphically with traffic-light colors in the topology.

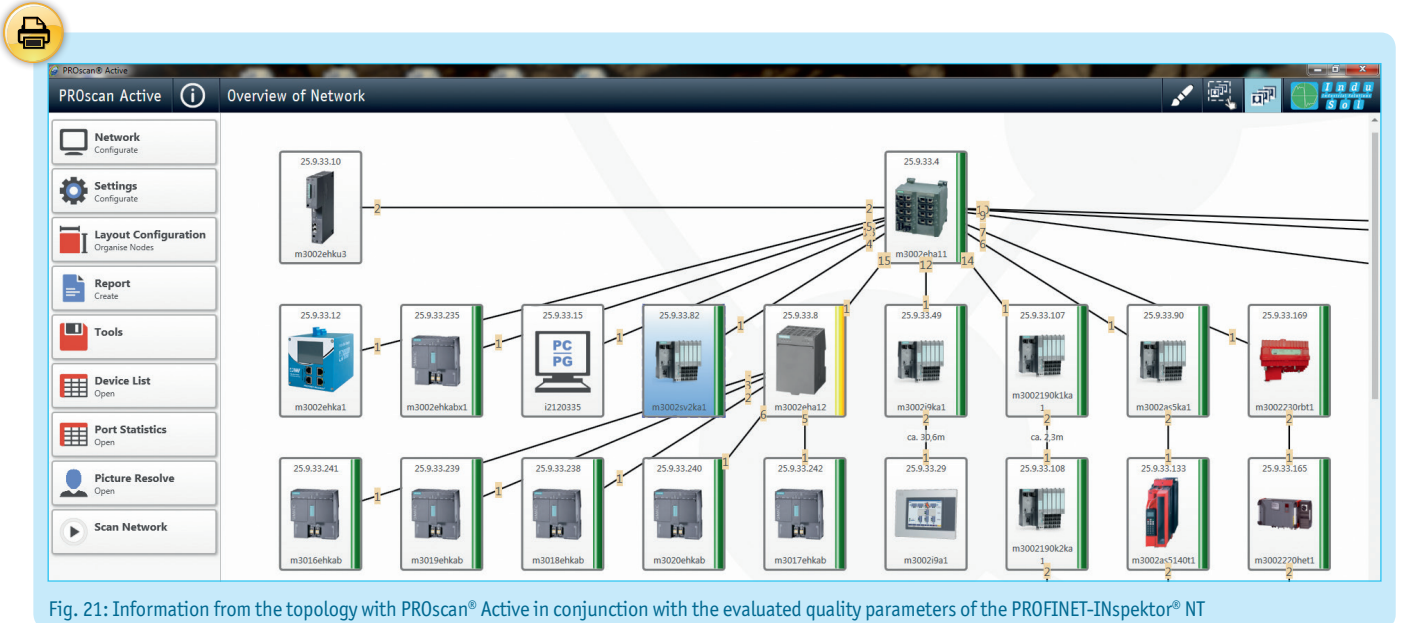

Fig. 21: Information from the topology with PROscan® Active in conjunction with the evaluated quality parameters of the PROFINET-INspektor® NT

PROFINET Diagnostic set



Highlights

- Online network diagnostics: **PROFINET-INspektor® NT**
- Topology software: **PROscan® Active**
- Network monitoring software: **PROmanage® NT**
- Leakage current measuring clamp: **EmCheck® LSMZ I**
- Cable diagnostics: **PROlinetest** or alternatively **ETHERtest V5.0** or **V5.1**

On request we will provide you with an instruction to the functions, benefits and uses of the complete contents of the **PROFINET Diagnostic set** (see page 25). This introduction is especially suitable for those in charge of commissioning, service and maintenance.

We will gladly provide a separate offer for individual devices (see page 24 ff.).

PROmanage® NT network monitoring software

For preventative, condition-oriented maintenance of PROFINET networks **Indu-Sol** has developed a strategy for permanent network monitoring (referred to as PNM in the following). It provides for condition monitoring with the goal of “warning before failure”.

The concept of PNM provides for a continuous network analysis with a decentral, passive data collector, the **PROFINET-INSpektor® NT**. Whenever preset threshold values are exceeded this event is stored together with a time stamp. The installation is between the controller and the first switch port. Each controller therefore requires an **INSpektor®**. With **PROmanage® NT** all external **INSpektors®** are integrated in the monitoring via the existing Ethernet network, and the network conditions are bundled centrally on a server. The network-specific events are pre-processed by the **PROFINET-INSpektor® NT** and provided chronologically by the **PROmanage® NT** network monitoring software for further processing and evaluation.

PROmanage® NT enables the evaluation, analysis and long-term storage of condition data for your fieldbuses and other industrial networks. For this purpose **PROmanage® NT** retrieves the port statistics of manageable switches and the events of the decentral data collectors (**INSpektors®**), evaluates them and displays them graphically.

This sophisticated method of analysis makes irregularities immediately apparent. When a value exceeds or falls below a configurable threshold value an alarm activates. The statistic function keeps data exact to the minute available up to one year. This means historical events can be opened up for viewing at any time for cause analysis, e.g. of sporadic failures.

Highlights

- Central monitoring of all fieldbuses and networks
- Avoid system failures
- Timely warning via OPC, SNMP trap or email in case of irregularities
- Data exact to the minute available up to one year
- Quick installation
- Easy device set-up due to automatic and manual device scan

To improve system availability the following targets are set for a PNM system:

- Continuous monitoring of real communication
- Complete monitoring and detection of causes of network weaknesses
- Automatic alarms when negative developments occur
- Central overview of all networks

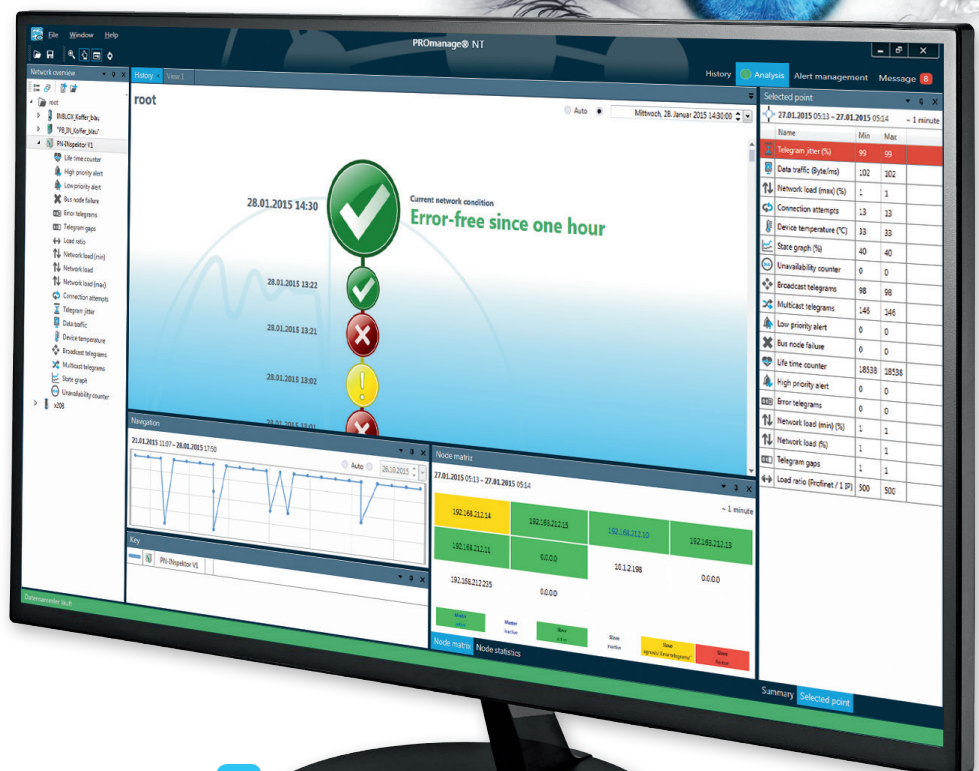



PROmanage® NT

Network history

How is my network?

The network history provides a quick and clear overview of:

- The current network status
- How long a network has run without error
- When the last error occurred (with time stamp)

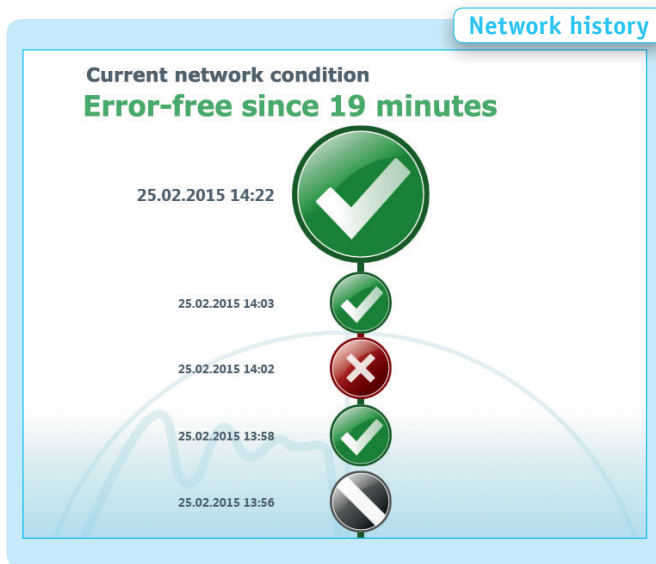

Network condition graph

A user-friendly interface can be used to display and evaluate the information. The interface can be adapted to your unique needs and spread over several physical screens for better overview.

Various parameters of different devices such as device temperature and failures can be compared in a graph to detect links in the event of malfunction.

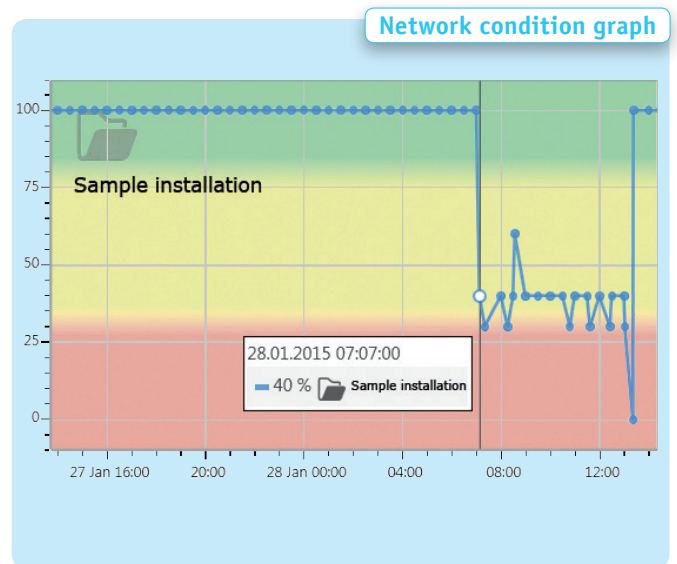

Event messages with time stamp

With the integrated threshold management threshold values can be defined for every network parameter. When a limit is reached an entry with a time stamp and event description is made automatically in the event list. Information about network errors can be retrieved from the event list with a mouse click.

Event messages with time stamp

Message type	Message	Date
Node	Threshold exceeded INBLOX 03 Segment 8 - Ch. 1 - DP Diag Parameter value 4 Threshold 1 Bus node restart	5/5/2015 12:26:00 PM
Node	Threshold exceeded INBLOX 03 Segment 8 - Ch. 1 - DP Diag Parameter value 4 Threshold 1 Repeat telegrams per bus cycle	5/5/2015 12:26:00 PM
Node	Threshold exceeded INBLOX 03 Segment 8 - Ch. 1 - DP Diag Parameter value 4 Threshold 1 Internal diagnosis	05.05.2015 12:26:00
Node	Threshold exceeded INBLOX 03 Segment 8 - Ch. 1 - DP Diag Parameter value 4 Threshold 1 External diagnosis	5/5/2015 12:26:00 PM

Alarm management

Integrated alarm management enables automatic forwarding of device notifications. By selecting suitable information medium (email, message services, OPC, SNMP) all messages can be transmitted to the responsible persons in a timely fashion. This shortens notification paths and prevents undesired plant breakdowns.

Alarm management

Available parameters

- ASi-Inspektor: High priority alert, Low priority alert, Bus node failure
- INBLOX: Error telegrams, Telegram gaps, Telegram overtakes, Load ratio
- PROFIBUS-Inspektor: Telegram jitter, Broad and Multicast telegrams, Device temperature
- PROFINET-Inspektor: Cycle time (max), Cycle time (min), Network load (max)
- PROFINET device/switch: Network load, Unavailability counter, State graph
- IP device: (empty)

Available traps

- Email
- OPC
- SNMP trap

PROFINET permanent network monitoring



Configuration example (PNM)

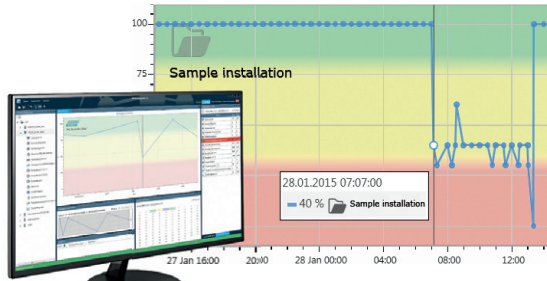

PROmanage[®] NT - external

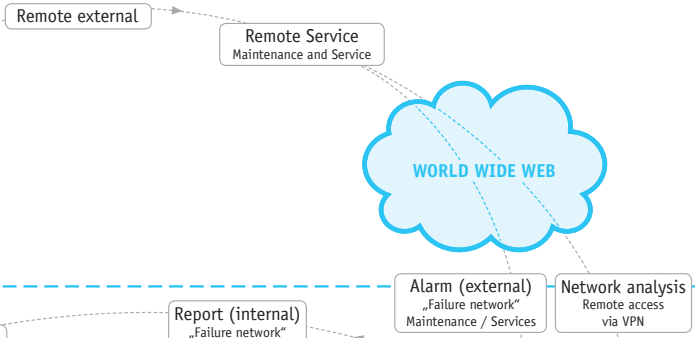

Control level

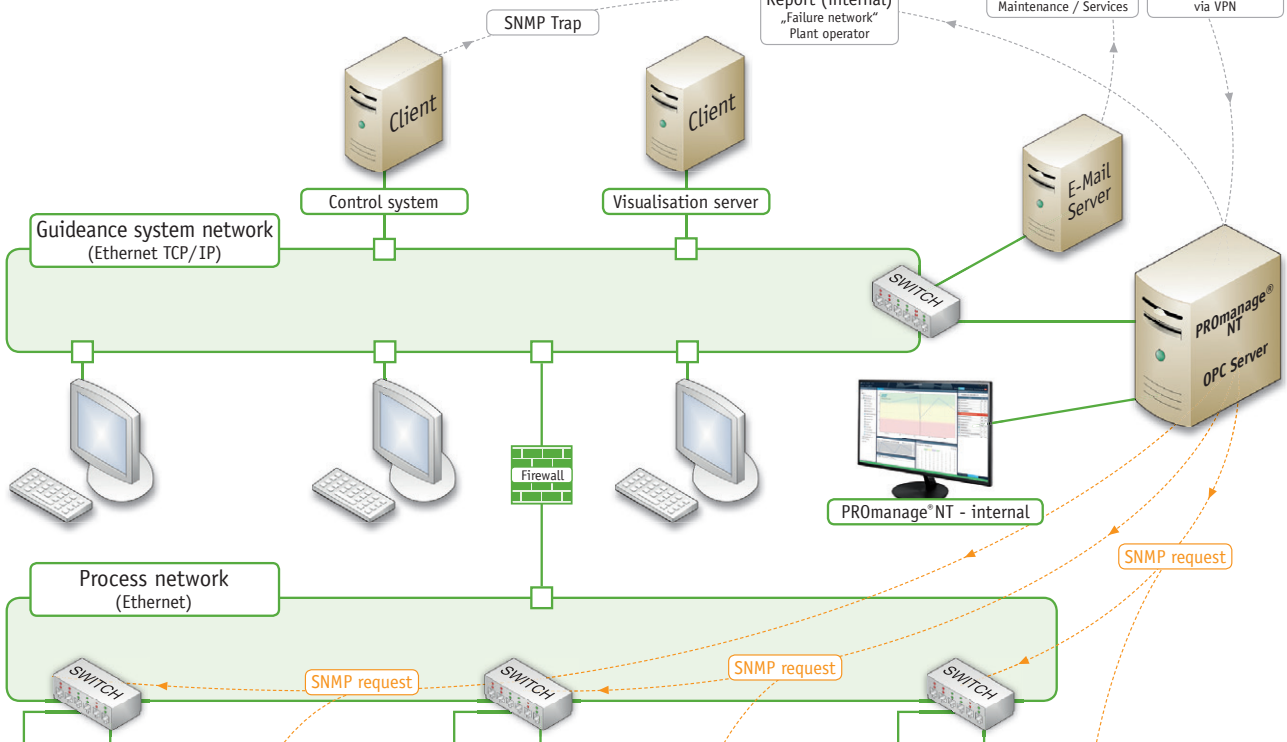

Functional group level

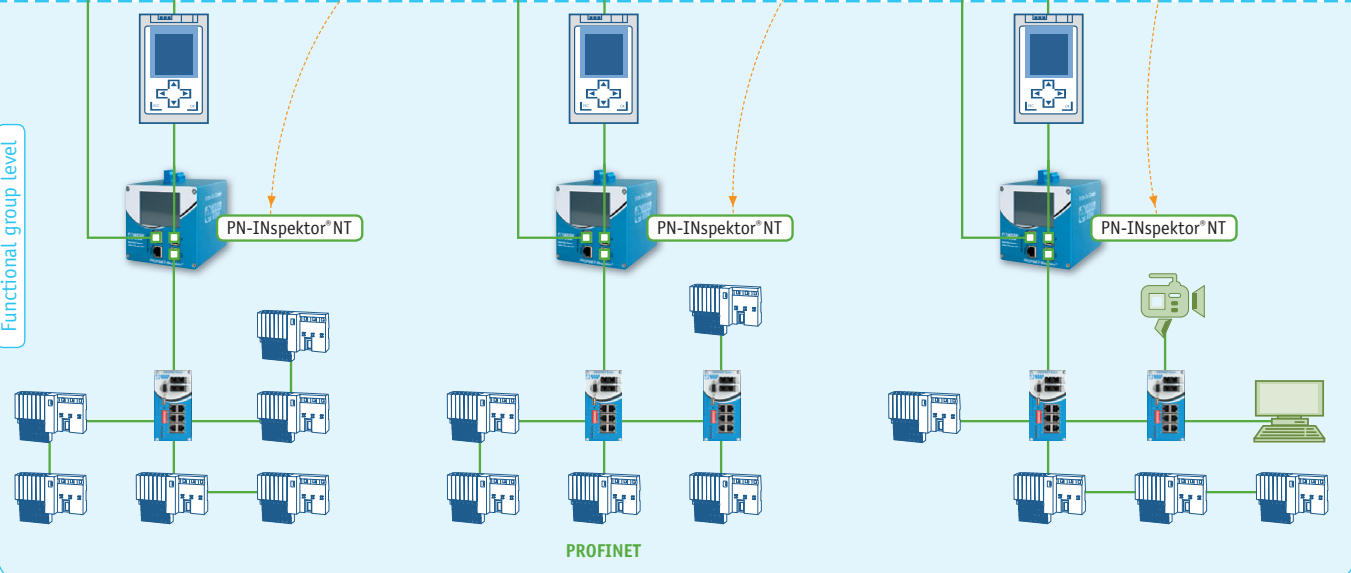

Consulting



Services include:

Based on years of experience we offer expert consultation in all matters related to fieldbuses and industrial data communication at all stages from the concept to practical use. We support you during network planning, documentation and commissioning. This includes e.g. the drafting of delivery specifications or product requirement documents. Our service also includes assembly supervision and the final acceptance and certification of your network. We offer training for your operating personnel to familiarize employees with the network specifications of your system.

We will gladly visit you for a “round table” and demonstrate the opportunities offered by our permanent network monitoring.

Measurement



Services include:

- Measurement of communication quality and creation of a measurement report
- Acceptance and certification of systems according to standards and PI guidelines
- Commissioning support
- Emergency support for troubleshooting
- Close-to-bus EMC evaluation / evaluation of equipotential bonding quality
- WLAN measurement incl. site survey

Training



Services include:

- Planning / installation / service
- Fundamentals of Ethernet / PROFINET / WLAN / EMC
- Practical network know-how (cables, plugs, structure, address assignment, commissioning etc. ...)
- Measurement devices / principles / methods / diagnostic options
- Practice (installation, telegram exchange, PNM, switch management, network security etc.)
- Certification of PROFINET installers

Network planning

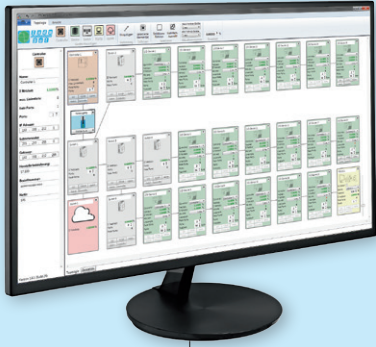

PROnetplan (see page 8)

Network planning software

Ordering Details	Art. No.
PROnetplan	114010009

Analysis | Diagnostics | Measurement



ETHERtest V5.0

ETHERtest V5.0 / V5.1 (see page 10)

PROFINET Line tester (suitable for certification)

Ordering Details	Art. No.
ETHERtest V5.0*	112010012
ETHERtest V5.1 (extendable for FOC)*	112010011



PROlinetest (see page 10)

PROFINET Line tester

Ordering Details	Art. No.
PROlinetest*	112010010



PROscan® Active (see page 11)

Active acceptance test and validation software

Ordering Details	Art. No.
PROscan® Active – 1x license (Basic license)	117000014
PROscan® Active – 5x license	117000018
PROscan® Active – 25x license	117000019

* All adapters for PROlinetest and ETHERtest V5.0/V5.1 on request.

Analysis | Diagnostics | Measurement

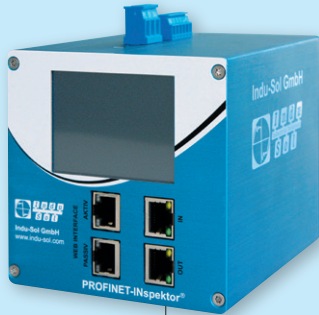

PROFINET INspektor® NT (see page 14)

Analysis and diagnostic tool

Ordering Details	Art. No.
PROFINET-INspektor® NT	124030100



PNMA II (see page 17)

PROFINET measuring point

Ordering Details	Art. No.
PNMA II	114090100



PROFINET DiagnosticDUO (see page 18)

PROscan® Active (1x license)

PROFINET-INspektor® NT

Ordering Details	Art. No.
PROFINET DiagnosticDUO	124030020



PROFINET Diagnostic set (see page 19)

All essential tools for commissioning and troubleshooting

- Analysis and diagnostic tool **PROFINET-INspektor® NT**
- Topology software **PROscan® Active**
- Network monitoring software **PROmanage® NT**
- Line tester **PROlinetest** (optionally incl. **ETHERtest V5.0/V5.1**)
- Leakage current measuring clamp **EmCheck® LSMZ I**

Ordering Details	Art. No.
PROFINET Diagnostic set (with PROlinetest)	114010020
PROFINET Diagnostic set (with ETHERtest V5.0)	114010030
PROFINET Diagnostic set (with ETHERtest V5.1)	114010040

Network monitoring

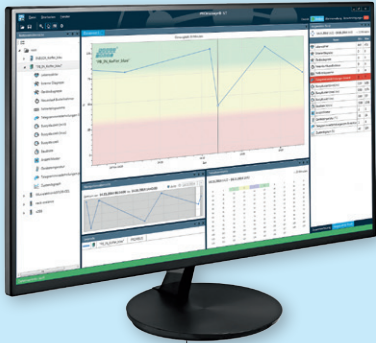

PROmanage® NT (see page 20)

Network monitoring software

*The licence defines the maximum number of network ports or devices retrieved simultaneously. (Ethernet switch: number of network ports = number of licence ports, 1 PB-INSPEKTOR® = 8 ports, 1 PN-INSPEKTOR® = 16 ports)

Ordering Details	Art. No.
PROmanage® NT (80 ports*)	117000032
PROmanage® NT (320 ports*)	117000034
PROmanage® NT (640 ports*)	117000036

EMC analysis | EMC diagnosis | EMC measurement



EmCheck® LSMZ I

Leakage current measuring clamp

Ordering Details	Art. No.
EmCheck® LSMZ I	122010005
Set of measuring clamps (LSMZ I and MWMZ II)	122010006



EmCheck® MWMZ II

Mesh resistance measuring clamp

Ordering Details	Art. No.
EmCheck® MWMZ II	122010010
Set of measuring clamps (LSMZ I and MWMZ II)	122010006

Infrastructure components



Switch

PROFINET switch (Conformity class B)

Ordering Details	Art. No.
PROFINET switch	112080005

Infrastructure components



PROFINET plugs

RJ45 / M12 Fast Connect

Ordering Details	Art. No.
PROFINET plug RJ45 (180°)	114030003
PROFINET plug RJ45 (90°)	114030004
PROFINET plug M12	114030002

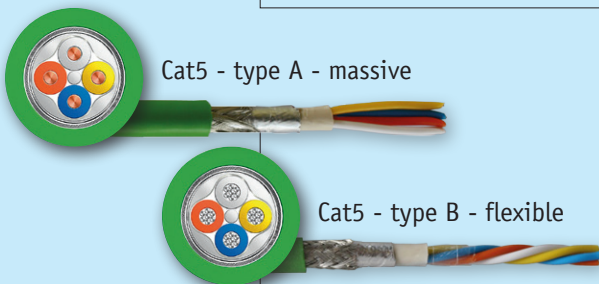

PROFINET cable

Cat5 massive / flexible

Ordering Details	Art. No.
PROFINET cable Cat5 (type A - massive)	114050001
PROFINET cable Cat5 (type B - flexible)	114060001

Services (Measurement/Training)

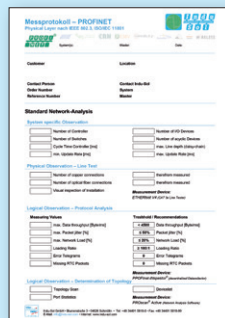

Measurement / Troubleshooting (see page 23)

Network analysis / Certification, Troubleshooting

Ordering Details	Art. No.
Network analysis/Certification	210030000
Troubleshooting	210030003

Training (see page 23)

PROFINET seminar (2 days)

Ordering Details	Art. No.
Training PROFINET (2 days-Schmoelln)*	220030001



Training (see page 23)

PROFINET seminar (PI certified incl. test)

Ordering Details	Art. No.
Certified PROFIBUS/PROFINET Installer (2,5 days-Schmoelln)*	220030007

Training (see page 23)

PROFINET WLAN

Ordering Details	Art. No.
Training WLAN (2 days - Schmoelln)*	220080001

* On-site training at your premises on request.

A large, stylized sun graphic in shades of green and teal, centered on the page. The sun has a circular core with several rays extending outwards, creating a sense of warmth and energy. The background is a solid teal color.

Indu-Sol GmbH
Blumenstrasse 3
04626 Schmoelln

Telephone: +49 (0) 34491 5818-0
Telefax: +49 (0) 34491 5818-99

info@indu-sol.com
www.indu-sol.com

Certified according to DIN EN ISO 9001:2008