

Anybus[®] Communicator[™] - Modbus RTU Server
to PROFIBUS
STARTUP GUIDE

SP3393

Version 1.0

Publication date 2025-04-07



Important User Information

Disclaimer

The information in this document is for informational purposes only. Please inform HMS Networks of any inaccuracies or omissions found in this document. HMS Networks disclaims any responsibility or liability for any errors that may appear in this document.

HMS Networks reserves the right to modify its products in line with its policy of continuous product development. The information in this document shall therefore not be construed as a commitment on the part of HMS Networks and is subject to change without notice. HMS Networks makes no commitment to update or keep current the information in this document.

The data, examples and illustrations found in this document are included for illustrative purposes and are only intended to help improve understanding of the functionality and handling of the product. In view of the wide range of possible applications of the product, and because of the many variables and requirements associated with any particular implementation, HMS Networks cannot assume responsibility or liability for actual use based on the data, examples or illustrations included in this document nor for any damages incurred during installation of the product. Those responsible for the use of the product must acquire sufficient knowledge in order to ensure that the product is used correctly in their specific application and that the application meets all performance and safety requirements including any applicable laws, regulations, codes and standards. Further, HMS Networks will under no circumstances assume liability or responsibility for any problems that may arise as a result from the use of undocumented features or functional side effects found outside the documented scope of the product. The effects caused by any direct or indirect use of such aspects of the product are undefined and may include e.g. compatibility issues and stability issues.

Copyright © 2025 HMS Networks

Contact Information

Postal address:

Box 4126

300 04 Halmstad, Sweden

E-Mail: info@hms.se

1. Preface

1.1. About This Document

This document describes how to install Anybus® Communicator™.

For additional documentation and software downloads, FAQs, troubleshooting guides and technical support, please visit www.hms-networks.com/technical-support.

1.2. Document Conventions

Safety Symbols

**DANGER**

Instructions that must be followed to avoid an imminently hazardous situation which, if not avoided, will result in death or serious injury.

**WARNING**

Instructions that must be followed to avoid a potential hazardous situation that, if not avoided, could result in death or serious injury.

**CAUTION**

Instruction that must be followed to avoid a potential hazardous situation that, if not avoided, could result in minor or moderate injury.

**IMPORTANT**

Instruction that must be followed to avoid a risk of reduced functionality and/or damage to the equipment, or to avoid a network security risk.

Information Symbols



NOTE

Additional information which may facilitate installation and/or operation.



TIP

Helpful advice and suggestions.

1.3. Trademarks

Anybus® is a registered trademark of HMS Networks.

All other trademarks are the property of their respective holders.

2. Safety

2.1. Intended Use

The intended use of this equipment is as a communication interface and gateway.

The equipment receives and transmits data on various physical layers and connection types.

If this equipment is used in a manner not specified by the manufacturer, the protection provided by the equipment may be impaired.

2.2. General Safety

**CAUTION**

Ensure that the power supply is turned off before connecting it to the equipment.

**CAUTION**

This equipment contains parts that can be damaged by electrostatic discharge (ESD). Use ESD prevention measures to avoid damage.

**CAUTION**

To avoid system damage, the equipment should be connected to ground.

**IMPORTANT**

Using the wrong type of power supply can damage the equipment. Ensure that the power supply is connected properly and of the recommended type.

3. Cybersecurity

3.1. General Cybersecurity



IMPORTANT

It is important to maintain the cybersecurity of the Communicator.

Before connecting the Communicator to a PLC, ensure the PLC is configured and installed in accordance with the PLC supplier hardening guidelines.



IMPORTANT

To physically secure networks and equipment and to prevent unauthorized access, it is recommended to install the equipment in a locked environment.



IMPORTANT

After completing the configuration of the Communicator, lock the security switch to prevent unauthorized access to the Communicator built-in web interface.



IMPORTANT

To avoid exposure of sensitive data, always perform a factory reset before decommissioning the equipment.

Factory reset will reset any on site made configuration changes and set the Communicator to the same state as leaving HMS production.

4. Preparation

4.1. Support and Resources

For additional documentation and software downloads, FAQs, troubleshooting guides and technical support, please visit www.hms-networks.com/technical-support.

**TIP**

Have the product article number available, to search for the product specific support web page. You find the product article number on the product cover.

4.2. Cabling

Have the following cables available:

- Power cable.
- Ethernet cable for configuration.
- PROFIBUS cable for connecting to network.
- 7-pin screw terminal block connector is included with the product.

4.3. Mechanical Tools and Equipment

Have the following tools available:

- Flat-head screwdriver, size 5.5 mm
Needed when removing the Communicator from DIN-rail.
Needed when changing the position of the rotary switches.
- Flat-head screwdriver, size 3 mm
Needed when connecting the cables to the 7-pin connector.

4.4. HMS Software Applications

Download the software installation files and user documentation from
www.hms-networks.com/technical-support.

HMS IPconfig

Use the software application HMS IPconfig and scan your network to discover and change the Communicator IP address and to access the Communicator built-in web interface.



NOTE

As an alternative, you can set a static IP address within the same IP address range as the Communicator IP address on the computer accessing the Communicator built-in web interface.



NOTE

HMS IPconfig is only available for Windows.

4.5. Software License Information

For license agreements regarding the third-party software used in the Communicator, refer to the *LICENSE.txt* file(s) included in the Communicator firmware update package zip file.

To download the Communicator firmware update package zip file, please visit
www.hms-networks.com/technical-support.



TIP

Have the product article number available, to search for the product specific support web page. You find the product article number on the product cover.

5. Installation

5.1. DIN Rail Mounting

**IMPORTANT**

The equipment must be electrically grounded through the DIN rail for EMC compliance. Make sure that the equipment is correctly mounted on the rail and that the rail is properly grounded.

**IMPORTANT**

To physically secure networks and equipment and to prevent unauthorized access, it is recommended to install the equipment in a locked environment.

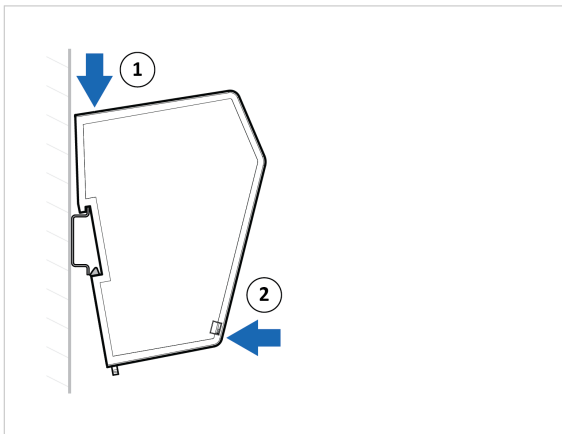

Figure 1. Attach the Communicator on the DIN rail

5.2. Connector Port Guide

This topic applies to different product variants for different networks.

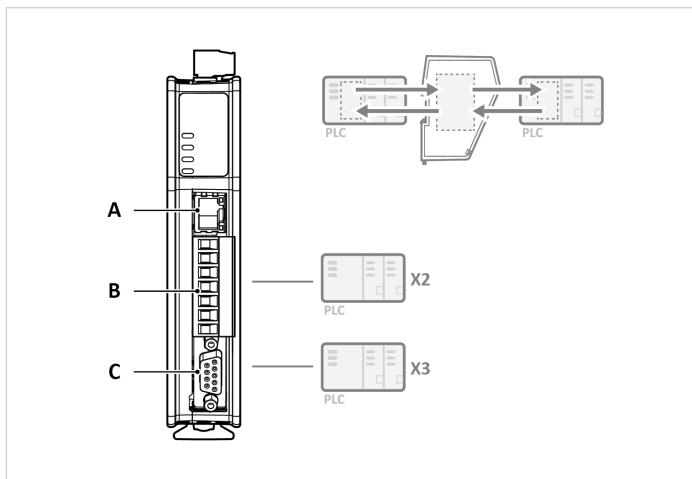

Figure 2. Communicator connector ports

Position	Port Number	Connector Type	Port Usage
A	X1	Ethernet RJ45	Configuration port
B	X2	7 Pin Screw Terminal Block	Modbus RTU network
C	X3	D-SUB	PROFIBUS network

5.3. Connect to Networks

5.3.1. Procedure

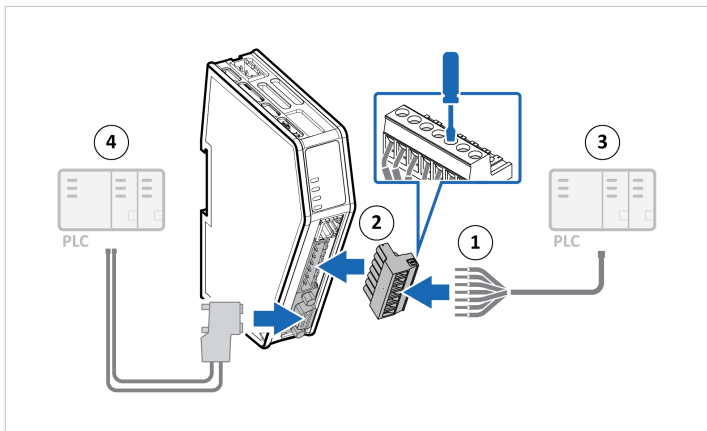

Figure 3. Connect Modbus RTU (3) and PROFIBUS (4)

Procedure

1. Insert the cable wires into the 7-pin connector and tighten the wire clamp screws (1). See [Modbus RTU Serial Connector Pinout \(page 10\)](#).
2. Connect the 7-pin connector to the Communicator (2).
3. Connect the Communicator to the Modbus RTU network (3).
4. Connect the Communicator to the PROFIBUS network (4).

5.3.2. Modbus RTU Serial Connector Pinout



NOTE

Use minimum 90 oC copper (Cu) wire only.

7-pin connector	Pin	Signal
	1	+5 V OUT
	2	RS485+ A
	3	RS485- B
	4	Signal GND
	5	Functional Earth (FE)
	6	RS232 Tx Transmit Data
	7	RS232 Rx Receive Data

5.3.3. PROFIBUS D-SUB Connector Pinout

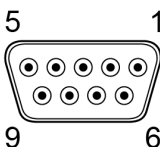
PROFIBUS Connector	Pin	Description
	1	Not used
	2	Not used
	3	Line B
	4	RTS
	5	GND Bus
	6	+5 V Bus Out
	7	Not used
	8	Line A
	9	Not used
	Housing	PE

5.4. Rotary Switch Settings

5.4.1. Rotary Switches Default Setting

By default, the value on the three rotary switches are set to **000**.

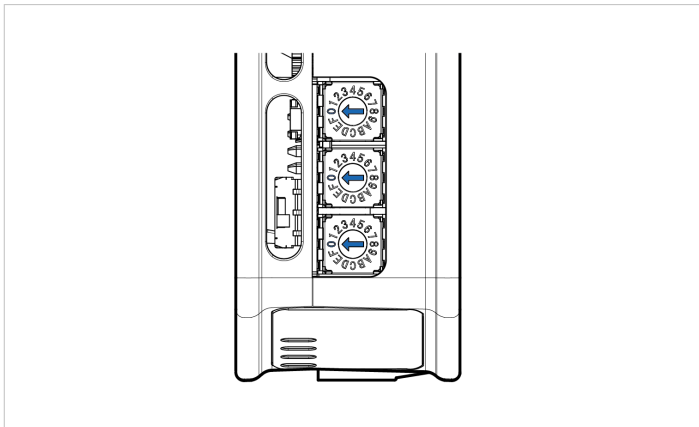

Figure 4. Rotary switches default setting **000**.

5.4.2. Set a Node Address with Rotary Switches

About the Rotary Switch Settings



TIP

Use Windows Calculator (or similar application) to convert between hexadecimal (hex) and decimal (dec).

- The default node address setting is 000.
- When the node address setting is 000, you can set the node address via the Communicator built-in web interface.
- The node address values are set in hexadecimal (hex).
- Minimum value is 00.
- Supports PROFIBUS node addresses 0-126 Dec (0-7E Hex).
- Each node address may only occur once in the network.
- The node address is read from the center rotary switch x16 to the front rotary switch x1.
- The rear rotary switch is not used, ensure that it is set to 0.

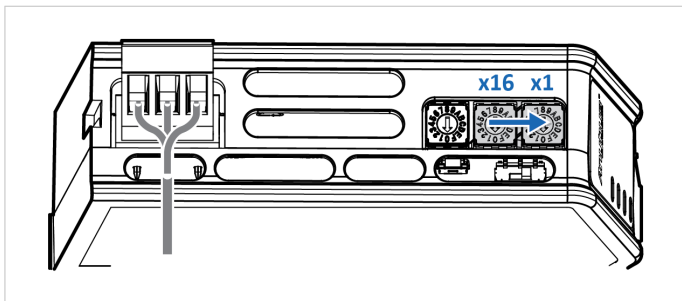

Before You Begin

Ensure that the Communicator is disconnected from power.

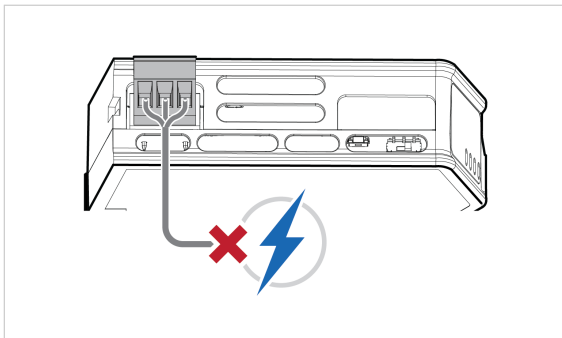
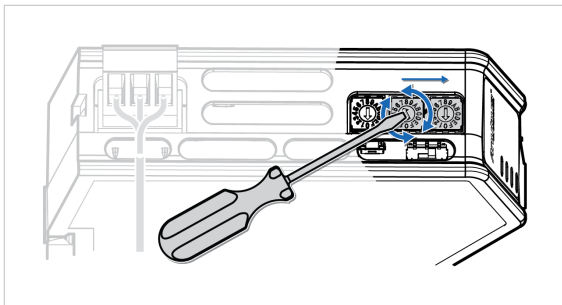

Figure 5. Disconnect Communicator from power

Procedure

Use a screwdriver to change the rotary switch position.

Ensure that the rotary switches engage correctly.



To Do Next

Connect the Communicator to power. See [Connect to Power \(page 16\)](#).

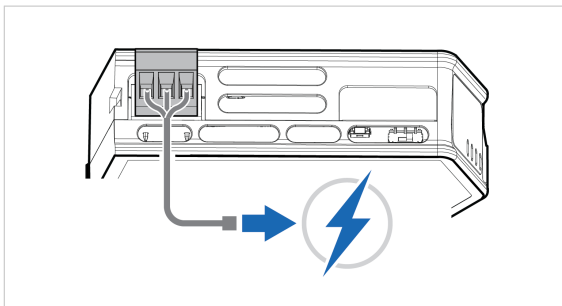

Figure 6. Connect Communicator to power

Result

The set node address is active as soon as the Communicator is powered on.

**NOTE**

Changing the address settings on the rotary switches during operation is ignored. For a new address to take effect, power cycle the Communicator.

5.5. Connect to Power



CAUTION

Ensure that the power supply is turned off before connecting it to the equipment.



IMPORTANT

Using the wrong type of power supply can damage the equipment. Ensure that the power supply is connected properly and of the recommended type.



IMPORTANT

Before you connect the Communicator to power, ensure that the PROFIBUS address is set on the rotary switches. If the PROFIBUS address is set when the Communicator is operating, you must power cycle the Communicator for the new setting to take effect.

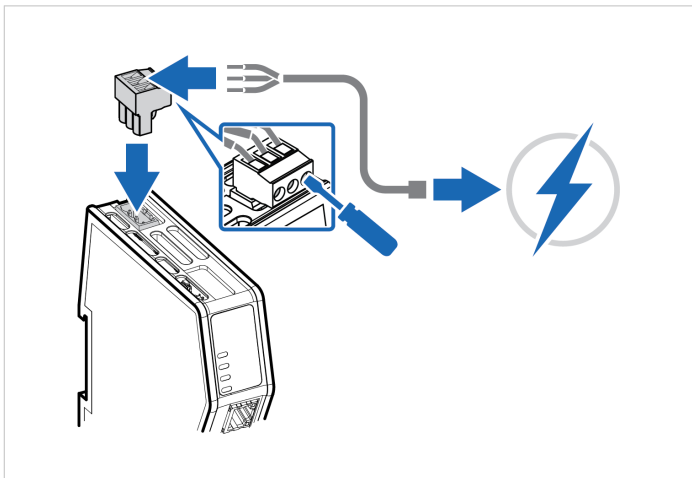

Figure 7. Connect to power

Power Connector Pinout

Power port	Pin	Description
	1	12-30 VDC Power Connector
	2	Ground (GND)
	3	Functional Earth (FE)

5.6. Security Switch



IMPORTANT

After completing the configuration of the Communicator, lock the security switch to prevent unauthorized access to the Communicator built-in web interface.

When the security switch is in its locked position, the Communicator built-in web interface cannot be accessed, and the Communicator cannot be configured using the built-in web interface. Network specific parameters, configured via the PLC is still available.

To Lock and Unlock the Security Switch

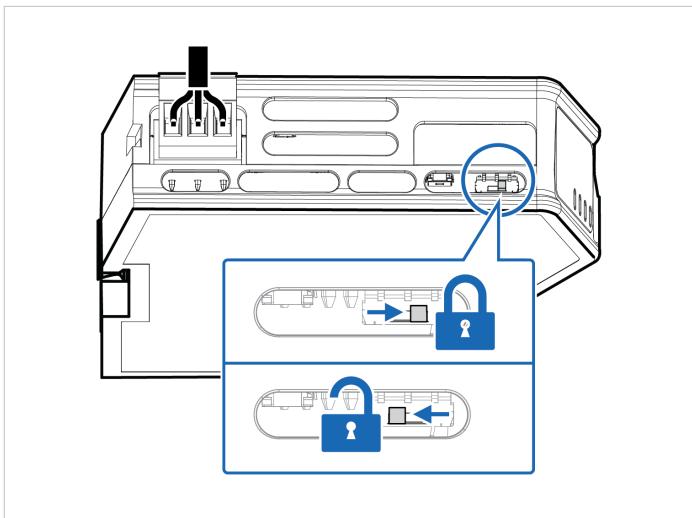

Figure 8. Security switch in locked and unlocked position

Use a pointed object, such as a ballpoint pen.

- To **lock** the security switch, push the toggle towards the **Communicator front**.
- To **unlock** the security switch, push the toggle towards the **Communicator back**.

Security Switch Status LED

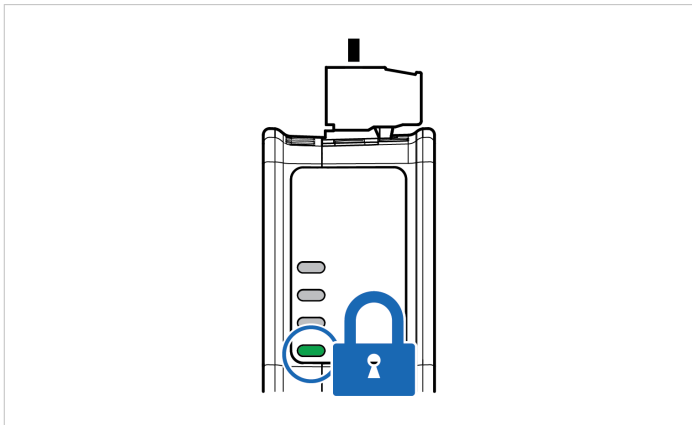

Figure 9. Security switch locked status LED

When the security switch is in its:

- locked position, the security switch status LED turn solid green.
- unlocked position, the security switch status LED is turned off.

5.7. Lock the Cables

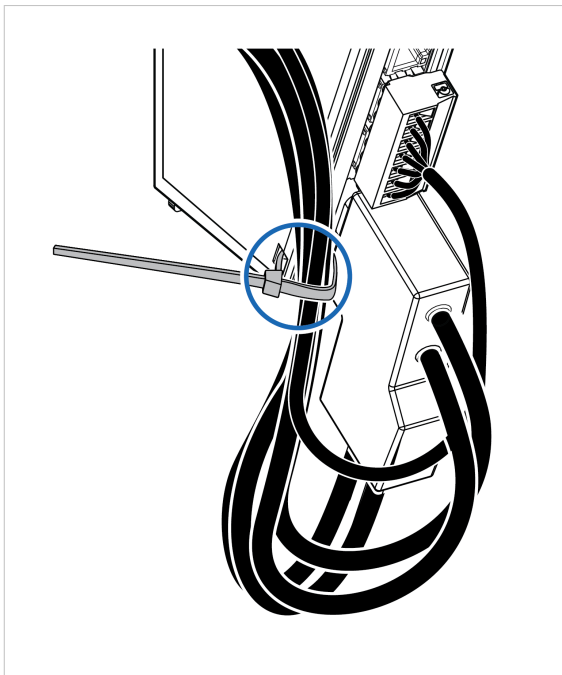

Figure 10. Lock the cables

To strain relieve the cables, place a cable tie in the holder and lock the cables.

5.8. DIN Rail Demount

Before You Begin



IMPORTANT

Be careful when removing the Communicator from the DIN-rail. If not removed properly, the DIN rail locking mechanism and the product cover can break.

Have a flat-blade screwdriver, size 5.5 mm, available.

Procedure

Remove the Communicator from the DIN rail:

1. Insert the screwdriver into the Communicator DIN rail locking mechanism.
2. To unlock the Communicator DIN rail locking mechanism, turn the screwdriver clockwise.

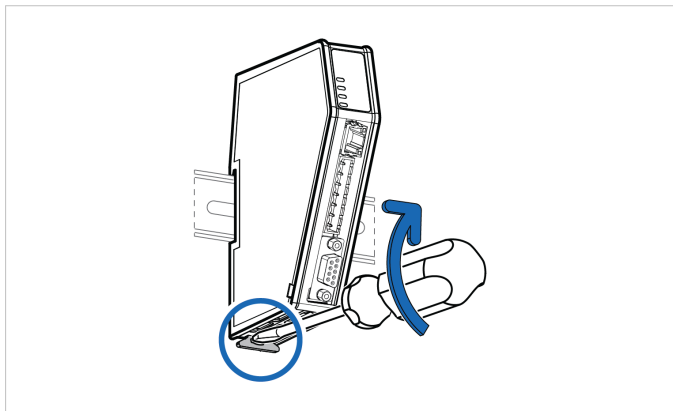

Figure 11. Unlock the Communicator

3. Hold the screwdriver in the DIN rail locking mechanism while you unhook the Communicator from the DIN rail.

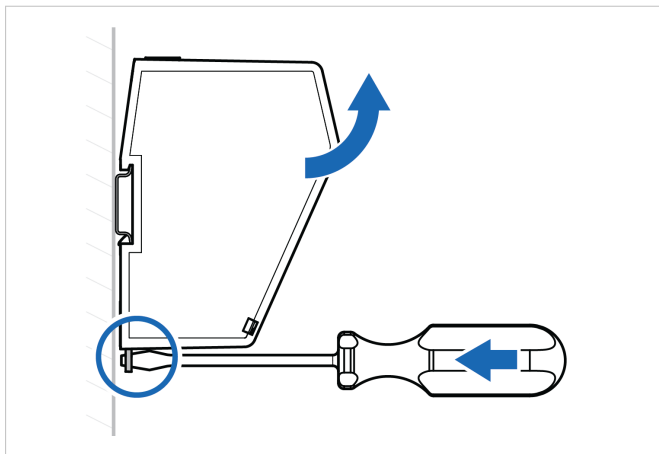

Figure 12. Unhook the Communicator

6. Configuration

6.1. Connect to PC and Power

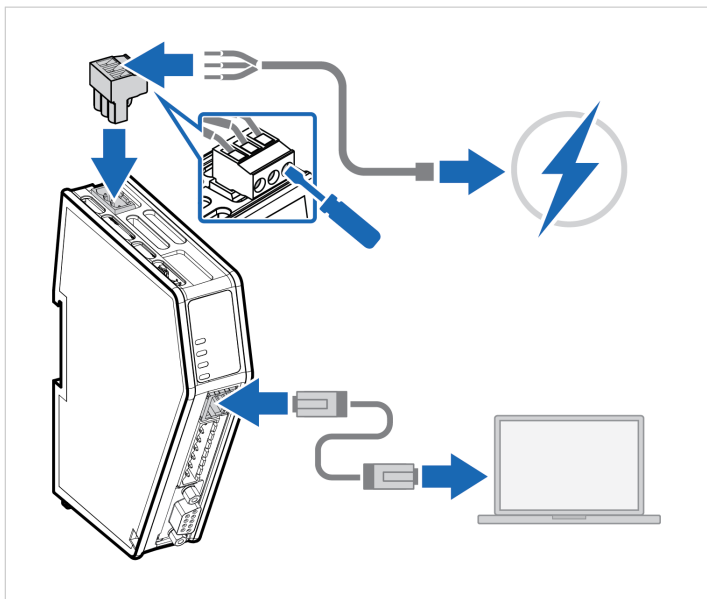

Figure 13. Connect to PC and Power

6.2. Find the Communicator on Your PC

The Communicator default IP address is 192.168.0.10.

To be able to access the Communicator built-in web interface you may need to adjust the IP settings, choose one of the following methods:

Option 1 | Set a static IP address on the PC



On the PC accessing the Communicator built-in web interface, set a static IP address within the same IP address range as the Communicator IP address.

To access the Communicator built-in web interface, ensure that port Port 80 TCP is open in your PC Windows Firewall.

Note that when you change to a static IP address on your PC, internet access is lost.

Option 2 | Change the IP address on the Communicator configuration port



Use the software application HMS IPconfig to find and change the IP address on the Communicator configuration port, to one within the same IP address range as the PC accessing the Communicator built-in web interface.

To download the installation files, please visit www.hms-networks.com/technical-support and enter the product article number to search for the Communicator support web page. You find the product article number on the product cover.

6.3. Configure the Communicator

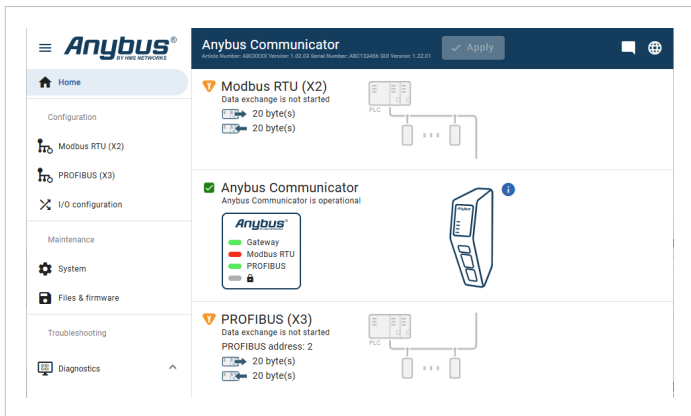



Figure 14. The Communicator built-in web interface Home page

Open the Communicator built-in web interface in HMS IPconfig or enter the Communicator IP address in your web browser.

The built-in web interface takes you through the steps to configure the Communicator.

Web Interface Language Settings

The default web interface language is **English**. To change language, click the **Language** icon  and select a new language from the list. The language change takes effect immediately.

Support and Resources

If you need more in-depth information about the configuration, please visit www.hms-networks.com/technical-support and enter the product article number to search for the Communicator support web page. You find the product article number on the product cover.

6.4. Change Language

Default language is **English**.

To change the language of the Communicator built-in web interface:

1. In the Communicator built-in web-interface header, click the **Language** icon .

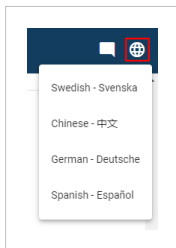

Figure 15. Language menu

2. Select a new language from the list.

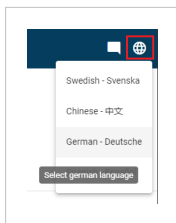

Figure 16. Example: Change language to German

The language change takes effect immediately.

7. Technical Data

For complete technical specifications and regulatory compliance information, please visit www.hms-networks.com.

7.1. Technical Specifications

Article identification	ABC4028
Configuration connector	RJ45
Upper connector	7-pin screw connector
Lower connector	9-pin D-sub
Power connector	3-pin screw connector
Power supply	12-30 VDC, Reverse voltage protection and short circuit protection
Power consumption	Typical: 90 mA @ 24 V (2.2 W) Max: 3 W
Storage temperature	-40 to +85 °C
Operating temperature	-25 to +70 °C
Humidity	EN 60068-2-78: Damp heat, +40°C, 93% humidity for 4 days EN 60068-2-30: Damp heat, +25°C – +55°C, 95% RH, 2 cycles
Vibration	See datasheet
Housing material	Plastic, See datasheet for details
Protection class	IP20
Product weight	150 g
Dimensions	27 x 144 x 98 mm (W x H x D) with connectors included
Mounting	DIN-rail

8. Communicator LED Indicators



NOTE

Before you can verify operation, you must configure the Communicator.

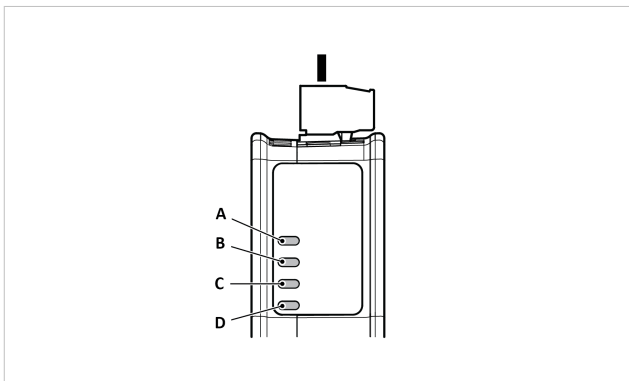

Figure 17. Gateway status (A), Lower connector (B), Upper connector (C) and Security Switch (D)

LED A - Gateway status	
Operation Status	Description
Off	No power
Green, flashing	Startup phase
Green, solid	Operational
Red, flashing	Invalid configuration
Green/Red, flashing	Power up self-test/Firmware update/Firmware recovery

LED B - PROFIBUS, Lower connectors		
LED C - Modbus RTU, Upper connector		
Operation status.	Modbus RTU	PROFIBUS
Off	No power, no active nodes, or all nodes are stopped.	No power/No data exchange.
Green, flashing	Waiting for first Modbus message.	Clear, data exchange.
Green, solid	At least one Modbus message received.	Operate, data exchange.
Red, solid	Fatal event.	
Red, one flash	N/A	Parameterization error.
Red, two flash	N/A	PROFIBUS configuration error.
Red, flashing	Connection timeout. No Modbus messages has been received within the configured process active timeout time.	N/A

Security switch - LED D	
Operation status	Description
Off	No power/Security switch is unlocked/Exception/Fatal error
Green	Security switch is locked

Fatal Error and Exception Error

Fatal error: A fatal error causes the Communicator firmware application to crash in an uncontrolled manner.

Exception error: An exception error causes the Communicator to enter a controlled error state. The Communicator firmware application is still running.

LED	Fatal error	Exception error
A	Red, solid	Red, solid
B	Red, solid	Off
C	Red, solid	Off
D	Off	Off

9. Ethernet LED Indicators

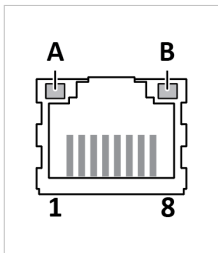

Figure 18. LED A. Activity LED B. Not used

LED A	Function
Off	No link (or no power)
Green	Link (100 Mbit/s) established
Green, flashing	Activity (100 Mbit/s)
Yellow	Link (10 Mbit/s) established
Yellow, flashing	Activity (10 Mbit/s)

LED B	Function
Off	Not used

This page is intentionally left blank.

This page is intentionally left blank.