



Anybus[®] Wireless Bridge II[™]

STARTUP GUIDE

SCM-1202-013/SP2167-EN 1.7 ENGLISH



Important User Information

Liability

Every care has been taken in the preparation of this document. Please inform HMS Industrial Networks AB of any inaccuracies or omissions. The data and illustrations found in this document are not binding. We, HMS Industrial Networks AB, reserve the right to modify our products in line with our policy of continuous product development. The information in this document is subject to change without notice and should not be considered as a commitment by HMS Industrial Networks AB. HMS Industrial Networks AB assumes no responsibility for any errors that may appear in this document.

There are many applications of this product. Those responsible for the use of this device must ensure that all the necessary steps have been taken to verify that the applications meet all performance and safety requirements including any applicable laws, regulations, codes, and standards.

HMS Industrial Networks AB will under no circumstances assume liability or responsibility for any problems that may arise as a result from the use of undocumented features, timing, or functional side effects found outside the documented scope of this product. The effects caused by any direct or indirect use of such aspects of the product are undefined, and may include e.g. compatibility issues and stability issues.

The examples and illustrations in this document are included solely for illustrative purposes. Because of the many variables and requirements associated with any particular implementation, HMS Industrial Networks AB cannot assume responsibility for actual use based on these examples and illustrations.

Intellectual Property Rights

HMS Industrial Networks AB has intellectual property rights relating to technology embodied in the product described in this document. These intellectual property rights may include patents and pending patent applications in the USA and other countries.

Anybus® is a registered trademark and Wireless Bridge II™ is a trademark of HMS Industrial Networks AB. All other trademarks mentioned in this document are the property of their respective holders.

1 Preparation

1.1 About This Document

This document describes how to install Anybus Wireless Bridge II and set up a basic configuration.

For additional documentation, configuration examples, FAQs, troubleshooting guides and technical support, please visit www.anybus.com/support.

1.2 Product Description

Anybus Wireless Bridge II provides wireless communication over WLAN and/or Bluetooth® to wired networks.

Typical applications for Anybus Wireless Bridge II include:

- Adding wireless cloud connectivity to industrial devices
- Accessing devices from a laptop, smartphone or tablet
- Ethernet cable replacement between devices

Limitations:

Bluetooth PAN (Personal Area Network) may not work with some devices due to different implementations of Bluetooth by different manufacturers.

WLAN 5 GHz cannot be used at the same time as WLAN 2.4 GHz or Bluetooth.

1.3 Model Name – Certification Identifier

The model name is used to identify the product for various certifications. It consists of a model prefix followed by two designators for the specific interface configuration and functionality.

Prefix	AWB3	Anybus Wireless Bridge II
Interface configuration	A B	Internal antenna (Closed Type), interfaces: Dual M12 External antenna (Open Type), interfaces: Dual M12, RP-SMA
Functionality	A B	Ethernet with digital input Ethernet w/o digital input

Example: AWB3AA = Anybus Wireless Bridge II with internal antenna, Ethernet networking and digital input.

2 Installation



Caution

This equipment emits RF energy in the ISM (Industrial, Scientific, Medical) band. Make sure that all medical devices used in proximity to this device meet appropriate susceptibility specifications for this type of RF energy.



Caution

The M12 power and LAN connectors must be provided with tool operated mechanical lock nuts that are tightened by the installer.



This product is recommended for use in both industrial and domestic environments. For industrial environments it is mandatory to use the functional earth connection to comply with immunity requirements. For domestic environments the functional earth must be omitted if a shielded Ethernet cable is used, in order to meet emission requirements.



This product contains parts that can be damaged by electrostatic discharge (ESD). Use ESD prevention measures to avoid damage.

Anybus Wireless Bridge II can be screw-mounted directly onto a flat surface or mounted on a standard DIN rail using the optional DIN mounting kit.

Make sure that you have all the necessary information about the capabilities and restrictions of your local network environment before installation.

For optimal reception, wireless devices require a zone between them clear of objects that could otherwise obstruct or reflect the signal. A minimum distance of 50 cm between the devices should also be observed to avoid interference.

The characteristics of the internal antenna should be considered when choosing the placement and orientation of the unit (unless an external antenna is used).

See the **Anybus Wireless Bridge II User Manual** for more information.

2.1 Dimensions

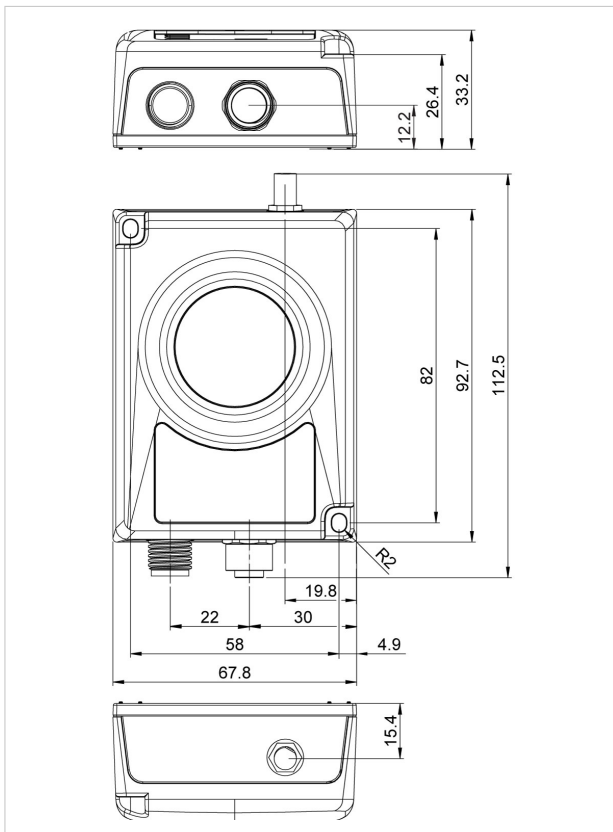

All measurements are in mm.

2.2 Connectors

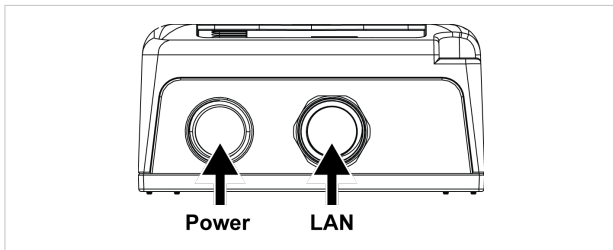

Power Connector (A-coded male M12)

	Pin	Function
	1	Power + (9–30 V)
	2	Digital Input Ground
	3	Power Ground
	4	Digital Input + (9–30 V)
	5	Functional Earth



Signal wiring for the digital input must be carried in the same cable as power and functional earth if wiring length exceeds 3 meters.

LAN Connector (D-coded female M12)

	Pin	Function	Color coding (T568B)
	1	Transmit +	Orange/White
	2	Receive +	Green/White
	3	Transmit -	Orange
	4	Receive -	Green

2.3 LED Indicators

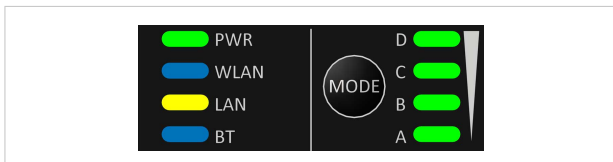

PWR	Off	No power
	Green	Normal operation
WLAN	Off	WLAN disabled or no power
	Blue, blinking	Access Point: No clients, awaiting connections
	Blue	Access Point: Connected to at least one client Client: Connected to access point
	Blue, flickering	WLAN data activity (when connected)
	Purple, blinking	Client: Scanning for access points
	Purple	Client: Connecting to a detected access point
	Red	Unrecoverable error
LAN	Off	No Ethernet connection
	Yellow	Ethernet link present
	Yellow, flickering	Ethernet data activity (when connected)
BT	Off	Bluetooth disabled or no power
	Blue, blinking	NAP: No clients, awaiting connections
	Blue	NAP: Connected to at least one PANU client PANU: Connected to NAP
	Blue, flickering	Bluetooth data activity (when connected)
	Purple	PANU: Trying to connect to NAP
	Red	Unrecoverable error

RSSI (WLAN Client) / Link Quality (Bluetooth PANU)

				No connection
A				RSSI/Link Quality < 25 %
A	B			RSSI/Link Quality 25–50 %
A	B	C		RSSI/Link Quality 50–75 %
A	B	C	D	RSSI/Link Quality > 75 %

Additional LED indications are used when the unit is in Recovery Mode.
See [Recovery Mode LED Indications, p. 12](#).

3 Configuration

Anybus Wireless Bridge II can be configured via the web interface or using one of the pre-configured **Easy Config** modes.

Advanced configuration can be carried out by issuing AT commands via the web interface or over a Telnet or RAW TCP connection to port 8080.

3.1 The Web Interface

The web interface is accessed by pointing your web browser to the IP address of the Wireless Bridge. The default address is **192.168.0.99**.

Most configuration settings are self-explanatory. See also the Anybus Wireless Bridge II User Manual.

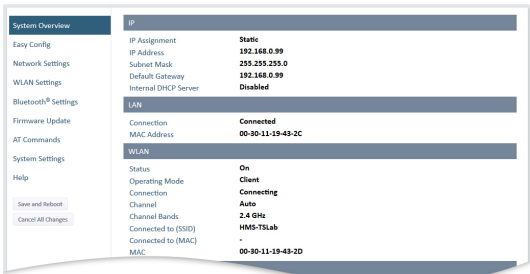

The screenshot shows the web interface configuration page. On the left is a sidebar with the following menu items: System Overview (selected), Easy Config, Network Settings, WLAN Settings, Bluetooth® Settings, Firmware Update, AT Commands, System Settings, Help, Save and Reboot, and Cancel All Changes. The main content area is titled 'System Overview' and contains three sections: IP, LAN, and WLAN.

IP	
IP Assignment	Static
IP Address	192.168.0.99
Subnet Mask	255.255.255.0
Default Gateway	192.168.0.99
Internal DHCP Server	Disabled

LAN	
Connection	Connected
MAC Address	00-30-11-19-43-2C

WLAN	
Status	On
Operating Mode	Client
Connection	Connecting
Channel	Auto
Channel Bands	2.4 GHz
Connected to (SSID)	HMS-TSLab
Connected to (MAC)	-
MAC	00-30-11-19-43-2D



The web interface is designed for the current stable versions of Internet Explorer, Chrome, Firefox and Safari. Other browser versions may not support all functions of the interface.

3.2 Easy Config

1. Power on the unit and wait for the **Link Quality** LEDs to light up and go out again, then immediately press and release the **MODE** button.
2. Press **MODE** repeatedly to cycle through the Easy Config modes until the desired mode is indicated by the **A-B-C-D** LEDs.
3. Within 20 seconds of step 2, press and hold **MODE** for 2 seconds. When the button is released the unit will restart in the selected mode.

Easy Config Modes

Mode	Role	Description	LED			
2	—	Reset configuration to factory defaults.		B		
3	—	Reset IP settings to factory defaults.	A	B		
4	Client	Wait for automatic configuration.			C	
5	WLAN AP	Configure units in mode 4 as clients.	A		C	
6	Bluetooth NAP	Restart as access point and connect clients.		B	C	
7	WLAN AP	Configure units in mode 4 as clients.	A	B	C	
8	Bluetooth NAP	Restart as access point and connect clients. Apply PROFINET optimizations to all units.				D
10	—	Apply PROFINET optimizations and restart.		B		D

Modes 5 – 8 will scan for units in mode 4. Detected units will be reconfigured as clients, and the scanning unit will restart as an access point. The clients will then restart and connect to the access point.

Modes 7 and 8 will additionally apply PROFINET optimization to all the units. PROFINET messages will then have priority over TCP/IP frames.

Mode Timeout

- Modes 5 – 8 will time out after 120 seconds. Apply the mode again to repeat the scan.
- Mode 4 will listen for 120 seconds or until receiving a configuration.



The IP address of a client may be changed by the configuration from the access point. Active browser sessions could therefore be lost.

3.3 Factory Restore

Any one of these actions will restore the factory default settings:

- Holding **MODE** pressed for >10 seconds and then releasing it
- Executing **Easy Config Mode 2**
- Clicking on **Factory Restore** on the **System Settings** page
- Issuing the AT command **AT&F** and then restarting the unit

Default Network Settings

IP Assignment	Static
IP Address	192.168.0.99
Subnet Mask	255.255.255.0
Default Gateway	192.168.0.99

Default WLAN Settings

Operating Mode	Client
Channel Bands	2.4 GHz & 5 GHz
Authentication Mode	WPA/WPA2-PSK
Channel	Auto
Bridge Mode	Layer 3 IP forward

Default Bluetooth Settings

Operating Mode	PANU (Client)
Local Name	[generated from MAC address]
Security Mode	Just works

Default System Settings

Password	[empty]
-----------------	---------



Setting a secure password for the unit is strongly recommended.

3.4 MODE Button

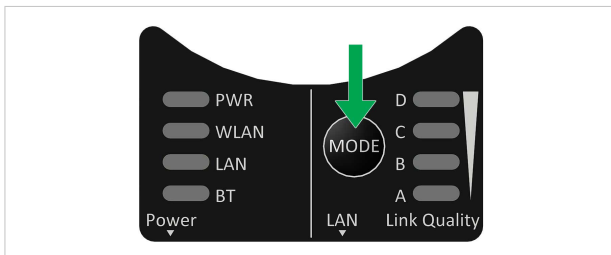

The **MODE** button can be used to restart or reset the unit as well as for selecting an Easy Config mode.

- ▶ Press and hold the button for >10 seconds and then release it to reset to the factory default settings (when the unit is powered on).
- ▶ Press and hold the button during startup to enter *Recovery Mode*.

Recovery Mode

If the web interface cannot be accessed, the unit can be reset by starting in Recovery Mode and reinstalling the firmware using Anybus Firmware Manager II, which can be downloaded from www.anybus.com/support.



Firmware updates should normally be carried out through the web interface. Recovery Mode should only be used if the unit is unresponsive and the web interface cannot be accessed.

Recovery Mode LED Indications

In Recovery Mode the LEDs will indicate firmware update status:

PWR	Green	Firmware update in progress
	Green, blinking	Waiting for valid firmware
WLAN + BT	Alternating red/blue	Firmware update in progress

3.5 Configuration Examples

More examples can be found at www.anybus.com/support.

3.5.1 Ethernet Bridge via WLAN or Bluetooth® Configuration with Easy Config

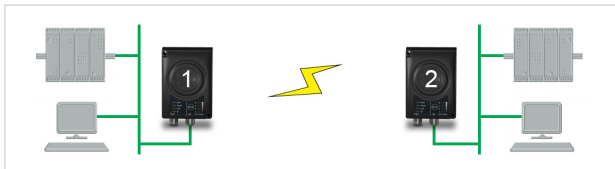

This example describes how to connect two Ethernet network segments via WLAN or Bluetooth using Easy Config.

Configuration

1. Power on the first unit and wait for the LEDs to light up and go out, then press **MODE** and release it immediately.
2. Press **MODE** repeatedly until only LED **C** is lit (Easy Config Mode 4), then confirm by pressing and holding **MODE** for 2 seconds.
This unit will now be discoverable and open for automatic configuration.
3. Power on the second unit and wait for the LEDs to light up and go out, then press **MODE** and release it immediately..
4. Press **MODE** repeatedly on the second unit until **A + C** are lit (Mode 5) for WLAN, or **B + C** (Mode 6) for Bluetooth, then confirm by pressing and holding **MODE** for 2 seconds.

This unit should now automatically discover and configure unit 1 as a WLAN or Bluetooth client, and configure itself as an access point.

Unit 1 will automatically be assigned the first free IP address within the same Ethernet subnet as unit 2.

Adding More Devices

Up to 6 additional clients can be added by repeating the procedure. Each new client will be assigned the next free IP address within the current subnet.

4 Technical Data

4.1 Technical Specifications

Order code	AWB3000	AWB3010
Wireless antenna	Internal	External
Maximum range	400 m (WLAN and Bluetooth) <i>Using an external antenna does not extend the range but allows separate placement of antenna and unit (e.g. if unit is placed in an enclosure).</i>	
Wired Interface type	Ethernet	
Communication	See Anybus Wireless Bridge II Datasheet	
Dimensions (LxWxH)	93 x 68 x 33.2 mm	
Weight	120 g	
Operating temperature	-40 to +65 °C	
Storage temperature	-40 to +85 °C	
Humidity	EN 600068-2-78: Damp heat, +40 °C, 93 % humidity for 4 days	
Pressure	850 to 1050 mB	
Housing	Plastic	
Protection class	IP65	
Mounting	Screw mount or DIN rail using optional clip	
Power connector	M12 male A-coded	
Ethernet connector	M12 female D-coded	
Power supply	9–30 VDC (-5 % +20 %) Cranking 12 V (ISO 7637-2:2011 pulse 4) Reverse polarity protection	
Power consumption	0.7 W (idle), 1.7 W (max)	
Certifications	See www.anybus.com/support and the compliance information appended to the User Manual.	

This page intentionally left blank

© 2018 **HMS Industrial Networks AB**
Box 4126
300 04 Halmstad, Sweden

info@hms.se

SCM-1202-013/SP2167-EN 1.7.7836 / 2018-03-14